

Viva 470.197120 / 470.207120

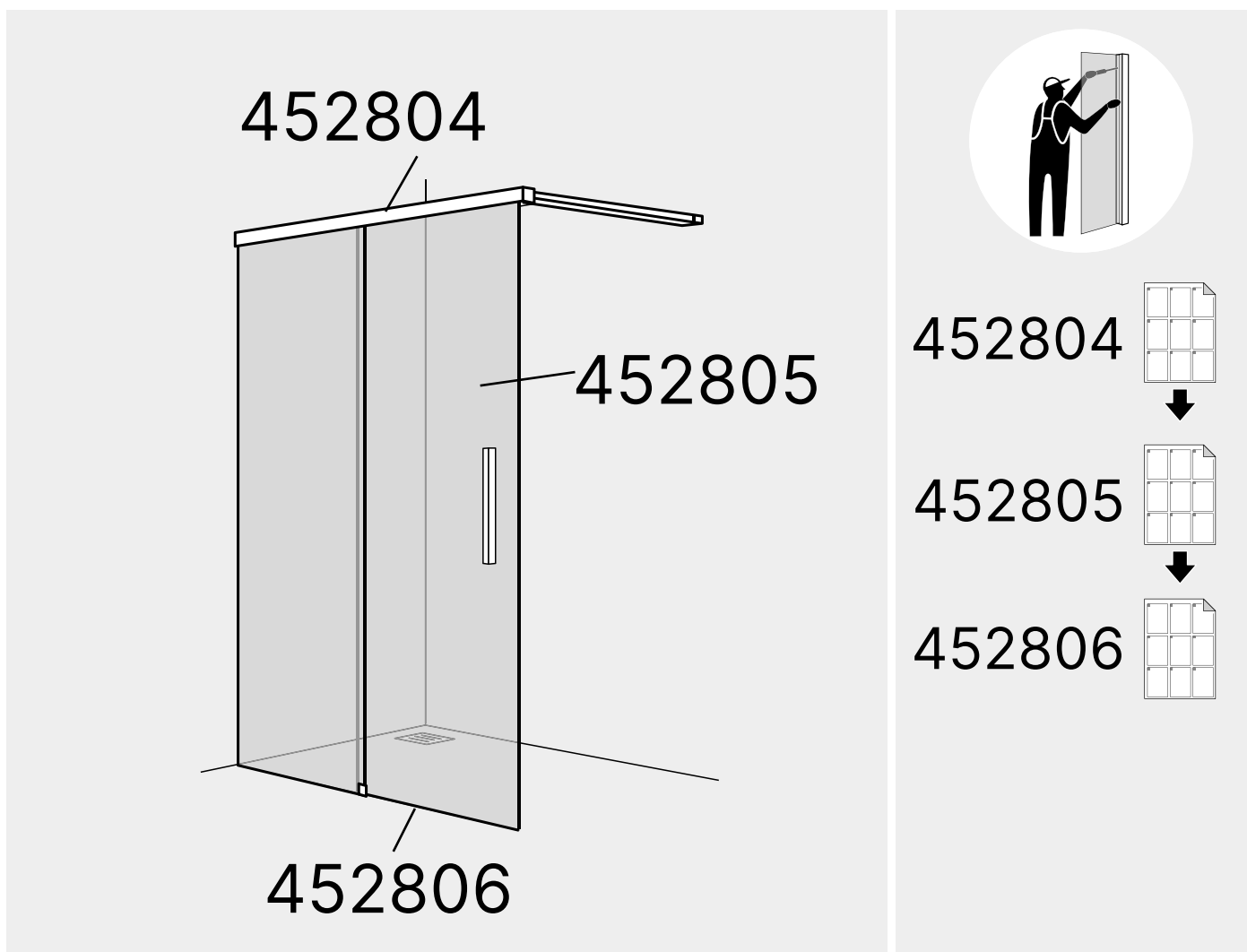

DE	Montageanleitung	Seite	2
EN	Installation instructions	Page	4
FR	Instruction de montage	Page	6
IT	Istruzione di montaggio	Pagina	8
ES	Instrucciones de montaje	Página	10

NL	Montagevoorschrift
CS	Montážní návod
SK	Návod na montáž
PL	Instrukcja montażu
NO	Monteringsveiledning
RU	Инструкция по монтажу



duscholux.com



Inhalt

1	Einführung	2
2	Allgemeine Sicherheitshinweise	2
3	Transport und Lagerung	2
4	Installation	2
5	Demontage und Entsorgung	3
6	Hilfe bei Störungen	3
7	Service und Ersatzteile	3
8	Checklisten	3

1 Einführung

1.1 Über diese Anleitung

Diese Montageanleitung richtet sich an den **Fachhandwerker**.

Sie enthält alle Informationen zur Installation der Duschtrennwände.

- Vor der Installation diese Anleitung lesen.
- Nach der Installation die Anleitung dem Endverbraucher überlassen.
- Anleitung aufbewahren und an den nächsten Benutzer weitergeben.
- Technische Änderungen sind vorbehalten.

Warnhinweise in dieser Anleitung



GEFAHR / WARNUNG / VORSICHT

Dieses Zeichen warnt vor Personenschäden.

Grafiken



- Montagegrafiken finden Sie am Ende dieser Anleitung.
- Beim betreffenden Arbeitsschritt wird auf die zugehörige Grafik verwiesen.

1.2 Bestimmungsgemäße Verwendung

- Die Duschtrennwand nur gemäß dieser Montageanleitung installieren. Jede andere Nutzung ist nicht bestimmungsgemäß.
- Die Duschtrennwand ist nur für den Hausgebrauch vorgesehen.

Fehlgebrauch

Umbauten und Änderungen an der Duschtrennwand sind nicht erlaubt.

1.3 Weiterführende Informationen

Unter **www.duscholux.com** finden Sie folgende Informationen:

- "Wichtige Produktinformationen" zu Reinigung und Pflege der Duschtrennwand
- Leistungserklärung

2 Allgemeine Sicherheitshinweise

- Die Duschtrennwand darf nur von einem **Fachhandwerker** montiert und installiert werden.
- Bei der Installation die einschlägigen gültigen Normen und Vorschriften beachten. Bei Fragen wenden Sie sich an Duscholux.
- Technische Änderungen oder Umbauten an der Duschtrennwand sowie der Betrieb einzelner Teile bzw. der Einbau in andere Produkte ist nicht zulässig.
- Für den richtigen Gebrauch und die Pflege der Duschtrennwand die betreffende Pflegeanleitung beachten.

3 Transport und Lagerung

- Die Duschtrennwand ist zerbrechlich: Produkt vorsichtig behandeln und keinen Stößen aussetzen.
- Duschtrennwand nur in der Originalverpackung transportieren und lagern.
- Duschtrennwand trocken lagern.

4 Installation

HINWEIS

Bruchgefahr

→ Duschtrennwand nicht auf die Kanten stellen.

4.1 Lieferumfang, Zubehör und benötigtes Werkzeug

→ Vor der Montage die Lieferung auf Schäden und Vollständigkeit prüfen.



Duscholux übernimmt keine Haftung für Schäden durch die Installation von erkennbar unvollständigen oder mangelhaften Produkten.

4.2 Montieren

→ Einbausituation auf lotrechten und waagerechten oder ebenen Zustand prüfen.



STROMSCHLAGGEFAHR GEFAHR VON WASSERSCHADEN

→ Sicherstellen, dass keine Strom- oder Wasserleitungen im Bohrbereich verlaufen.



Das beigegefügte Befestigungsmaterial ist für Wände aus festem Mauerwerk.

→ Befestigungsmaterial auf Eignung prüfen und ggf. auf die bauliche Situation abstimmen.

Duschtrennwand einsetzen und verfugen

→ Siehe Montagebilder.

HINWEIS

Gefahr von Undichtigkeiten oder Schimmelpilzbildung

→ Vor dem Verfugen Schienen und Wannenrand entfetten.

→ Nur Sanitär silikon nach EN15651-3 verwenden.

4.3 Reinigen

HINWEIS

Beschädigung der Duschtrennwand

→ Verwenden Sie keine scheuernden, lösungsmittel- oder chlorhaltigen Reinigungsmittel und keine aggressiven Säuren oder Laugen.

→ Beachten Sie die separate Anleitung "Wichtige Produktinformationen" zur Pflege und Reinigung von Duscholux-Duschtrennwänden.

4.4 Übergeben

→ Gehen Sie anhand der „Checkliste Übergabe“ in Abschnitt 8.3 vor.

5 Demontage und Entsorgung

Verpackung

→ Entsorgen Sie die Verpackung gemäß den lokalen Vorschriften.

Duschtrennwand

1. Demontieren Sie die Duschtrennwand.
2. Geben Sie die Duschtrennwand an Duscholux zurück.

6 Hilfe bei Störungen



Für Rückfragen stehen wir unter der in der Produktinformation zur Pflege und Reinigung angegebenen Adresse zur Verfügung.

7 Service und Ersatzteile

→ Ersatzteile siehe Bild .



- Unter dem DUSCHOLUX-Schild finden Sie die Garantienummer. Damit können Sie Garantiefälle abwickeln und 10 Jahre lang Ersatzteile nachkaufen. Das DUSCHOLUX-Schild bitte nicht entfernen.
- Für Rückfragen stehen wir unter der in der Produktinformation zu Pflege und Reinigung angegebenen Adresse zur Verfügung.

8 Checklisten

8.1 Checkliste Anschlussvoraussetzungen

Sanitärinstallation

Duschwanne montiert und abgedichtet

Dusche/Duschbereich verfließt

8.2 Checkliste Montage/Installation

Befestigungsmaterial geeignet?

Einbausituation lotrecht / waagrecht und eben

8.3 Checkliste Übergabe

Gereinigt

Funktion geprüft

Übergabe: "Wichtige Produktinformationen" zur Reinigung und Pflege

Hinweis: Silikonfugen regelmäßig prüfen

Übergabe der Montageanleitung, Hinweis: Montageanleitung aufbewahren

Ort, Datum, Uhrzeit

Firma

Name

Unterschrift

Contents

1	Introduction	4
2	General safety precautions	4
3	Transport and storage	4
4	Installation	4
5	Removal and disposal	5
6	Troubleshooting	5
7	Service and spare parts	5
8	Checklists	5

1 Introduction

1.1 About these instructions

These installation instructions are intended for **professional installers**.

They contain all information required for the installation of the shower panel.

- Read these instructions before carrying out the installation.
- Following the installation, pass on the instructions to the end consumer.
- Save the instructions and pass them on to the subsequent user.
- We reserve the right to make technical changes.

Warnings in these instructions



DANGER / WARNING / CAUTION

This symbol warns of personal injury.

Diagrams



- Installation diagrams can be found at the end of these instructions.
- Individual work steps refer to their respective diagrams.

1.2 Intended use

- The shower partition may only be installed in accordance with these installation instructions. Any other use is considered unintended.
- The shower partition is intended for domestic use.

Improper use

The shower partition may not be retrofitted or modified.

1.3 Additional information

You can find the following information at

www.duscholux.com:

- "Important product information" on the cleaning and care of the shower partition
- Declaration of performance

2 General safety precautions

- The shower partition may only be mounted and installed by a **professional tradesperson**.
- During the installation, comply with the applicable valid standards and regulations. Should you have any questions, contact Duscholux.
- Technical changes or retrofits to the shower partition and the operation of individual parts or their installation in other products is not permissible.
- Observe the respective care instructions for the proper usage and care of the shower partition.

3 Transport and storage

- The shower partition is fragile. It must be handled carefully and not subjected to impacts.
- The shower partition may only be transported and stored in its original packaging.
- Store the shower partition in a dry place.

4 Installation

NOTE

Risk of breaking

→ Do not place the shower partition on its edges.

4.1 Scope of delivery, accessories and required tools

→ Before carrying out mounting work, check the delivery for damage and completeness.



Duscholux assumes no liability for damage should identifiably incomplete or defective products be installed.

4.2 Mounting

→ Check the installation position for proper vertical, horizontal and level orientation.



RISK OF ELECTRIC SHOCK

RISK OF WATER DAMAGE

→ Ensure that there are no power or water lines in the drilling area.

- i** The accompanying fastening materials are for walls made of solid masonry.
 → Check the fastening materials for suitability and match to the installation situation if necessary.

Inserting and grouting the shower partition

→ See assembly illustrations.

NOTE

Risk of leaks or mold growth

- Degrease the rails and the edge of the tub before grouting.
 → Only plumbing silicone in accordance with EN15651-3 may be used.

4.3 Cleaning

NOTE

Damage to the shower partition

- Do not use abrasive cleaning agents or cleaning agents containing solvents or chlorine for cleaning. Likewise, do not use aggressive acids or lyes.
 → Observe the separate instructions entitled "Important product information" for the care and cleaning of Duscholux shower partitions.

4.4 Transfer

→ Proceed according to the "Transfer checklist" in Section 8.3.

5 Removal and disposal

Packaging

→ Dispose of the packaging in accordance with local regulations.

Shower partition

1. Remove the shower partition.
2. Return the shower partition to Duscholux.

6 Troubleshooting

- i** Should you have any questions, we can be reached at the address provided in the product information on care and cleaning.

7 Service and spare parts

→ For spare parts, see Figure .



- The warranty number can be found under the DUSCHOLUX plate. This number can be used for the processing of warranty claims and purchase of spare parts for a period of 10 years. Please do not remove the DUSCHOLUX plate.
- Should you have any questions, we can be reached at the address provided in the product information on care and cleaning.

8 Checklists

8.1 Connection requirement checklist

Plumbing installation

Shower tub mounted and sealed	<input type="checkbox"/>
Shower/shower area tiled	<input type="checkbox"/>

8.2 Mounting/installation checklist

Are the fastening materials suitable for mounting?	<input type="checkbox"/>
Installation position is vertical/horizontal and level	<input type="checkbox"/>

8.3 Transfer checklist

Cleaned	<input type="checkbox"/>
Operation has been checked	<input type="checkbox"/>
Transfer: "Important product information" on cleaning and care	<input type="checkbox"/>
Note: Check silicone grout regularly	<input type="checkbox"/>
Transfer of the installation instructions Note: Installation instructions saved	<input type="checkbox"/>

City, date, time	Company
------------------	---------

Name	Signature
------	-----------

Sommaire

1	Introduction.....	6
2	Consignes générales de sécurité.....	6
3	Transport et stockage	6
4	Installation.....	6
5	Démontage et élimination	7
6	Aide en cas d'incidents	7
7	Service après-vente et pièces de rechange.....	7
8	Listes de contrôle.....	7

1 Introduction

1.1 A propos de ces instructions

Ces instructions de montage s'adressent à l'**artisan spécialisé**.

Elles contiennent toutes les informations pour l'installation des parois de douche.

- Lire ces instructions avant l'installation.
- Après l'installation, remettre les instructions à l'utilisateur final.
- Conserver les instructions et les remettre à l'utilisateur suivant.
- Sous réserve de modifications techniques.

Indications d'avertissement dans ces instructions



DANGER / AVERTISSEMENT / ATTENTION
Ce sigle avertit de dommages corporels.

Graphiques



- Vous trouverez les illustrations de montage à la fin de ces instructions.
- Lors de l'étape de travail correspondante, il est fait référence à l'illustration applicable.

1.2 Utilisation conforme

- Installer la paroi de douche uniquement conformément à ces instructions de montage. Toute autre utilisation est non conforme.
- La paroi de douche est prévue uniquement pour un usage domestique.

Utilisation non conforme

Les transformations et modifications de la paroi de douche ne sont pas autorisées.

1.3 Informations complémentaires

Sur www.duscholux.com, vous trouverez les informations suivantes:

- "Informations de produit importantes" concernant le nettoyage et l'entretien de la paroi de douche
- Déclaration des performances

2 Consignes générales de sécurité

- La paroi de douche peut uniquement être montée et installée par un **artisan spécialisé**.
- Lors de l'installation, tenir compte des normes et prescriptions en vigueur. En cas de questions, veuillez vous adresser à Duscholux.
- Les modifications techniques ou transformations de la paroi de douche ainsi que l'utilisation de composants individuels ou leur montage dans d'autres produits n'est pas admissible.
- Pour l'utilisation correcte et l'entretien de la paroi de douche, tenir compte des instructions d'entretien correspondantes.

3 Transport et stockage

- La paroi de douche est fragile: manipuler le produit avec précaution et ne pas l'exposer à des chocs.
- Transporter et stocker la paroi de douche uniquement dans l'emballage d'origine.
- Stocker la paroi de douche au sec.

4 Installation

INDICATION

Risque de bris

→ Ne pas placer la paroi de douche sur chant.

4.1 Etendue de la livraison, accessoires et autre outillage

→ Avant le montage, contrôler que la livraison est complète et sans dommage.



Duscholux décline toute responsabilité pour les dommages dus à l'installation de produits visiblement incomplets ou défectueux.

4.2 Montage

→ Contrôler que la situation de montage est d'aplomb et horizontale ou plane.

**DANGER D'ÉLECTROCUTION
DANGER DE DÉGÂTS DES EAUX**

→ S'assurer qu'il n'y a pas de lignes électriques ni de conduites d'eau dans la zone de perçage.



Le matériel de fixation joint est prévu pour des murs en maçonnerie pleine.
→ Contrôler l'aptitude du matériel de fixation et l'adapter le cas échéant à la situation constructive.

Mettre en place et jointoyer la paroi de douche

→ Voir les schémas de montage.

INDICATION**Danger de fuites ou de formation de moisissures.**

- Avant le jointoiment, dégraisser les rails et le bord du receveur.
- Utiliser uniquement du silicone sanitaire selon EN15651-3.

4.3 Nettoyage**INDICATION****Détérioration de la paroi de douche**

- N'utilisez pas de produits de nettoyage abrasifs ni contenant des solvants ou du chlore ni d'acides ou lessives agressives.
- Tenez compte des instructions séparées "Informations de produit importantes" concernant l'entretien et le nettoyage des parois de douche Duscholux.

4.4 Transmission

→ Procédez selon la "Liste de contrôle de transmission" à la section 8.3.

5 Démontage et élimination**Emballage**

→ Éliminez l'emballage conformément aux prescriptions locales.

Paroi de douche

1. Démontez la paroi de douche.
2. Renvoyez la paroi de douche à Duscholux.

6 Aide en cas d'incidents

Pour toutes questions, nous sommes à votre disposition à l'adresse indiquée dans les informations de produit concernant l'entretien et le nettoyage.

7 Service après-vente et pièces de rechange

→ Pièces de rechange, voir illustration



- Vous trouverez le numéro de garantie en dessous du logo DUSCHOLUX. Il vous permet de régler les cas de garantie et de racheter des pièces de rechange pendant 10 ans. Veuillez ne pas enlever le logo DUSCHOLUX.
- Pour toutes questions, nous sommes à votre disposition à l'adresse indiquée dans les informations de produit concernant l'entretien et le nettoyage.

8 Listes de contrôle**8.1 Liste de contrôle des conditions de raccordement****Installation sanitaire**

receveur de douche monté et étanché	<input type="checkbox"/>
Douche/zone de douche carrelée	<input type="checkbox"/>

8.2 Liste de contrôle de montage/installation

Matériel de fixation approprié?	<input type="checkbox"/>
Situation de montage d'aplomb/horizontale et plane	<input type="checkbox"/>

8.3 Liste de contrôle de transmission

Nettoyé	<input type="checkbox"/>
Fonction contrôlée	<input type="checkbox"/>
Transmission: "Informations de produit importantes" concernant le nettoyage et l'entretien	<input type="checkbox"/>
Indication: Contrôler régulièrement les joints en silicone	<input type="checkbox"/>
Transmission des instructions de montage Indication: Conserver les instructions de montage	<input type="checkbox"/>

Lieu, date, heure	Société
-------------------	---------

Nom	Signature
-----	-----------

Contenuto

1	Introduzione.....	8
2	Avvisi di sicurezza generali	8
3	Trasporto e immagazzinamento.....	8
4	Installazione.....	8
5	Smontaggio e smaltimento	9
6	Guida all'eliminazione di guasti	9
7	Assistenza e parti di ricambio.....	9
8	Check list	9

1 Introduzione

1.1 Generalità sulle presenti istruzioni

Le presenti istruzioni di montaggio si rivolgono a **installatori specializzati**.

Contengono tutte le informazioni necessarie per installare

le pareti divisorie doccia.

- Prima di procedere all'installazione, leggere le presenti istruzioni.
- Al termine dell'installazione consegnare le istruzioni all'utente finale.
- Conservare le istruzioni e consegnarle all'utente successivo.
- Ci riserviamo la facoltà di apportare modifiche tecniche.

Avvisi di pericolo nelle presenti istruzioni



PERICOLO / AVVERTENZA / ATTENZIONE

Questo simbolo segnala la possibilità di riportare lesioni.

Illustrazioni



- Le illustrazioni esplicative del montaggio si trovano alla fine delle presenti istruzioni.
- Nella descrizione delle singole operazioni di montaggio si rimanda alle corrispondenti illustrazioni.

1.2 Uso conforme

- Installare la parete divisoria doccia solo conformemente alle presenti istruzioni di montaggio. Ogni altro utilizzo è considerato improprio.
- La parete divisoria doccia è destinata solo all'uso domestico.

Uso errato

Modifiche arbitrarie o non autorizzate della parete divisoria doccia non sono consentite.

1.3 Ulteriori informazioni

Nel sito www.duscholux.com sono disponibili le seguenti informazioni:

- "Importanti informazioni sul prodotto" per la pulizia e la cura della parete divisoria doccia
- Dichiarazione di prestazione

2 Avvisi di sicurezza generali

- La parete divisoria doccia deve essere montata e installata solo da un **installatore specializzato**.
- Per l'installazione attenersi alle normative e alle disposizioni valide specifiche. Per eventuali domande si prega di rivolgersi a Duscholux.
- Non è consentito né apportare modifiche tecniche arbitrarie o non autorizzate alla parete divisoria doccia né l'uso o il montaggio di suoi singoli componenti in altri prodotti.
- Per l'uso e la cura corretti della parete divisoria doccia attenersi alle sue istruzioni per la cura.

3 Trasporto e immagazzinamento

- La parete divisoria doccia è fragile: trattare il prodotto delicatamente e con cautela e non esporlo a urti.
- Trasportare e immagazzinare la parete divisoria doccia solo nell'imballaggio originale.
- Immagazzinare la parete divisoria doccia in un ambiente asciutto.

4 Installazione

AVVISO

Pericolo di rottura

- Non appoggiare la parete divisoria doccia sui suoi bordi.

4.1 Componenti forniti, accessori e utensili necessari

- Prima di procedere al montaggio, verificare l'integrità e la completezza dei componenti.



Duscholux declina qualsiasi responsabilità per gli eventuali danni subiti a causa dell'installazione di prodotti manifestamente incompleti o difettosi.

4.2 Montaggio

- Verificare che le pareti siano perfettamente verticali e il pavimento perfettamente orizzontale e piano.

**PERICOLO DI FOLGORAZIONE ELETTRICA
PERICOLO DI DANNI CAUSATI DALL'ACQUA**

→ Assicurarsi che nei punti in cui si realizzano i fori non passino cavi elettrici o tubi dell'acqua sotto traccia.



Il materiale di fissaggio in dotazione è adatto per pareti in muratura.

→ Controllare l'idoneità del materiale di fissaggio e, se necessario, adattarlo alla struttura edilizia.

Montare la parete divisoria doccia, stuccare e sigillare

→ Vedere le figure.

AVVISO**Pericolo di anemeticità o di formazione di muffa**

→ Prima di stuccare e sigillare, ingrassare le guide e la parete divisoria doccia.

→ Utilizzare solo silicone per sanitari secondo EN15651-3.

4.3 Pulizia**AVVISO****Danneggiamento della parete divisoria doccia**

→ Non utilizzare detergenti abrasivi o contenenti solventi o cloro e nemmeno sostanze acide o basiche aggressive.

→ Per la cura e la pulizia delle pareti divisorie doccia Duscholux attenersi alle apposite istruzioni "Importanti informazioni sul prodotto".

4.4 Consegna all'utente finale

→ Procedere sulla base della "Check list consegna all'utente finale" nella sezione 8.3.

5 Smontaggio e smaltimento**Imballaggio**

→ Smaltire l'imballaggio conformemente alle disposizioni locali.

Parete divisoria doccia

1. Smontare la parete divisoria doccia.
2. Restituire la parete divisoria doccia a Duscholux.

6 Guida all'eliminazione di guasti

Per domande e chiarimenti si prega di rivolgersi all'indirizzo indicato nelle informazioni sulla cura e pulizia del prodotto.

7 Assistenza e parti di ricambio

→ Per le parti di ricambio vedere la figura



- Il numero di garanzia si trova sotto la targhetta DUSCHOLUX. Con esso si possono espletare correttamente le operazioni connesse ai casi di garanzia e acquistare le parti di ricambio per 10 anni. Si prega di non rimuovere la targhetta DUSCHOLUX.
- Per domande e chiarimenti si prega di rivolgersi all'indirizzo indicato nelle informazioni sulla cura e pulizia del prodotto.

8 Check list**8.1 Check list condizioni di allacciamento****Impianto sanitario**

Piatto doccia montato e sigillato	<input type="checkbox"/>
Doccia/zona doccia piastrellata	<input type="checkbox"/>

8.2 Check list montaggio/installazione

Materiale di fissaggio idoneo?	<input type="checkbox"/>
Pareti verticali e pavimento orizzontale e piano	<input type="checkbox"/>

8.3 Check list consegna all'utente finale

Pulizia effettuata	<input type="checkbox"/>
Funzionamento controllato	<input type="checkbox"/>
Consegna: "Importanti informazioni sul prodotto" per la pulizia e la cura	<input type="checkbox"/>
Avviso: Controllare periodicamente i giunti di silicone	<input type="checkbox"/>
Consegna delle istruzioni di montaggio Avviso: Conservare le istruzioni di montaggio	<input type="checkbox"/>

Luogo, data, ora

Società

Nome

Firma

Índice

1	Introducción.....	12
2	Instrucciones generales de seguridad	12
3	Transporte y almacenamiento.....	12
4	Instalación	12
5	Desmontaje y eliminación	13
6	Ayuda en caso de averías.....	13
7	Servicio técnico y recambios.....	13
8	Listas de comprobación.....	13

1 Introducción

1.1 Acerca de estas instrucciones

Estas instrucciones de montaje van dirigidas al **técnico especializado**.

Incluye toda la información necesaria para realizar la instalación de las mamparas.

- Antes de realizar la instalación, se deberán leer estas instrucciones.
- Después de la instalación, se deberán entregar las instrucciones al usuario final.
- Conserve las instrucciones y entréguelas al siguiente usuario.
- Queda reservado el derecho a realizar modificaciones técnicas.

Indicaciones de advertencia en estas instrucciones



PELIGRO / ADVERTENCIA / ATENCIÓN

Este símbolo advierte de posibles daños personales.

Gráficos



- Al final de estas instrucciones encontrará gráficos descriptivos para el montaje.
- En cada paso de trabajo se hace referencia al gráfico correspondiente.

1.2 Uso previsto

- La mampara solo debe instalarse de acuerdo con las indicaciones de estas instrucciones de montaje. Cualquier uso diferente se considerará como no conforme al uso previsto.
- La mampara solo está prevista para el uso doméstico.

Uso incorrecto

No está permitido realizar reformas ni modificaciones en la mampara.

1.3 Información adicional

En la página **www.duscholux.com** encontrará la siguiente información:

- "Información importante sobre el producto" para la limpieza y el cuidado de la mampara
- Declaración de rendimiento

2 Instrucciones generales de seguridad

- La mampara solo debe montarse e instalarse por un **técnico especializado**.
- Para la instalación deben tenerse en cuenta las normas y prescripciones válidas aplicables. En caso de dudas, póngase en contacto con Duscholux.
- No está permitida la realización de modificaciones o reformas técnicas en la mampara, ni el uso de piezas individuales o el montaje en otros productos.
- Para realizar un uso y un cuidado correctos de la mampara, deberán tenerse en cuenta las instrucciones de cuidado correspondientes.

3 Transporte y almacenamiento

- La mampara es frágil: Manipule el producto con cuidado y evita que sufra golpes.
- La mampara solo debe transportarse y almacenarse en el embalaje original.
- Almacene la mampara en lugar seco.

4 Instalación

NOTA

Peligro de rotura

→ No apoye la mampara sobre los bordes.

4.1 Volumen de suministro, accesorios y herramientas necesarias

→ Antes de realizar el montaje, se deberá comprobar la presencia de posibles daños y la integridad del suministro.



Duscholux no asumirá ninguna responsabilidad por los daños que se produzcan como consecuencia de la instalación de productos visiblemente incompletos o defectuosos.

4.2 Montaje

→ Compruebe la alineación vertical y horizontal o nivelada de la situación de montaje.



PELIGRO DE DESCARGA ELÉCTRICA PELIGRO DE DAÑOS POR AGUA

→ Asegúrese de que por la zona de taladrado no pasan cables eléctricos o tuberías de agua.



El material de fijación suministrado está previsto para paredes de mampostería fija.
→ Compruebe la adecuación del material de fijación y, en caso necesario, adáptelo a la situación constructiva.

Colocación y sellado de las juntas de la mampara

→ Véanse las imágenes de montaje.

NOTA

Peligro de fugas o de formación de moho

- Antes de realizar el sellado de las juntas, elimine la grasa de los raíles y del borde de la bañera.
- Utilice solamente silicona para instalaciones sanitarias según la norma EN15651-3.

4.3 Limpieza

NOTA

Daños en la mampara

- No utilice productos de limpieza abrasivos, con contenido de disolvente o de cloro y no utilice ácidos o lejías agresivos.
- Tenga en cuenta las instrucciones separadas "Información importante sobre el producto" para la limpieza y el cuidado de mamparas de Duscholux.

4.4 Entrega

→ Proceda conforme a la "Lista de comprobación de entrega" en el apartado 8.3.

5 Desmontaje y eliminación

Embalaje

→ Elimine el embalaje de acuerdo con las prescripciones locales.

Mampara

1. Desmonte la mampara.
2. Devuelva la mampara a Duscholux.

6 Ayuda en caso de averías



Para cualquier pregunta, estaremos a su disposición en la dirección indicada en la información del producto para el cuidado y la limpieza.

7 Servicio técnico y recambios

→ Para consultar los recambios, véase la imagen 



- Debajo de la placa de DUSCHOLUX encontrará el número de la garantía. Con este número podrá tramitar los casos de uso de la garantía y podrá adquirir recambios durante un periodo de 10 años. La placa de DUSCHOLUX no deberá retirarse.
- Para cualquier pregunta, estaremos a su disposición en la dirección indicada en la información del producto para el cuidado y la limpieza.

8 Listas de comprobación

8.1 Lista de comprobación para los requisitos de conexión

Instalación de sanitarios

Plato de ducha montado y estanqueizado	<input type="checkbox"/>
Ducha/espacio de la ducha alicatados	<input type="checkbox"/>

8.2 Lista de comprobación para el montaje/la instalación

¿El material de fijación es adecuado?	<input type="checkbox"/>
Situación de montaje vertical/horizontal y nivelada	<input type="checkbox"/>

8.3 Lista de comprobación para la entrega

Limpio	<input type="checkbox"/>
Funcionamiento comprobado	<input type="checkbox"/>
Entrega: "Información importante sobre el producto" para la limpieza y el cuidado	<input type="checkbox"/>
Nota: Comprobar las juntas de silicona regularmente	<input type="checkbox"/>
Entrega de las instrucciones de montaje Nota: Guardar las instrucciones de montaje	<input type="checkbox"/>

Lugar, fecha, hora Empresa

Nombre Firma

452804

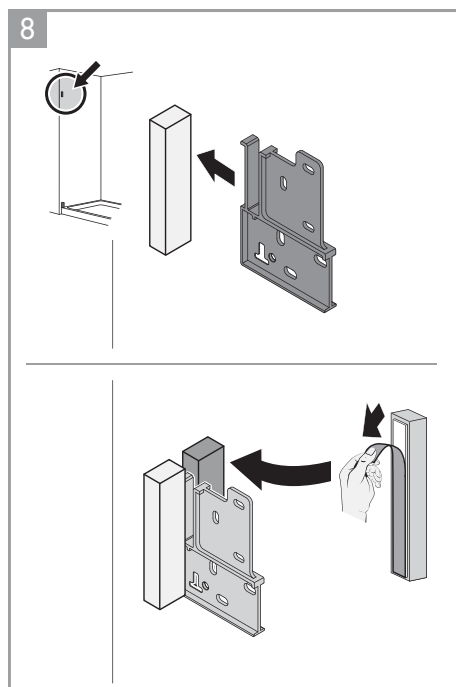
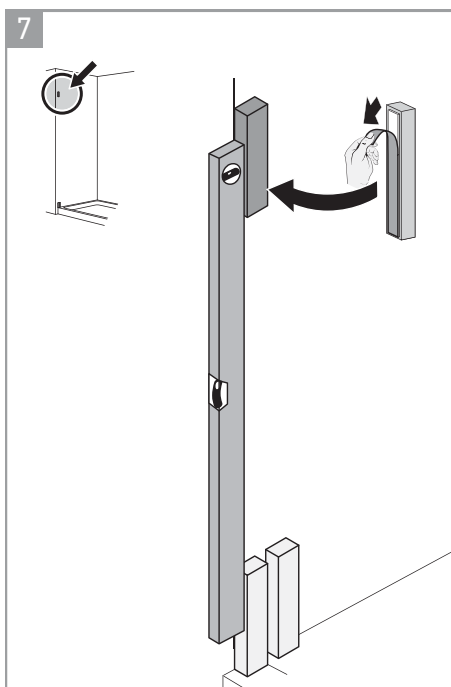
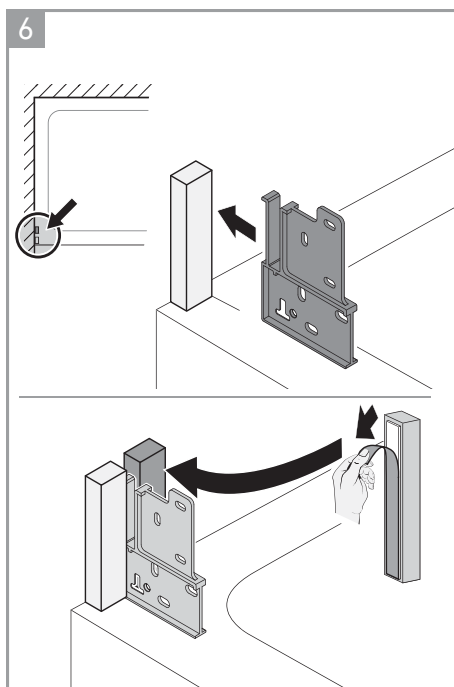
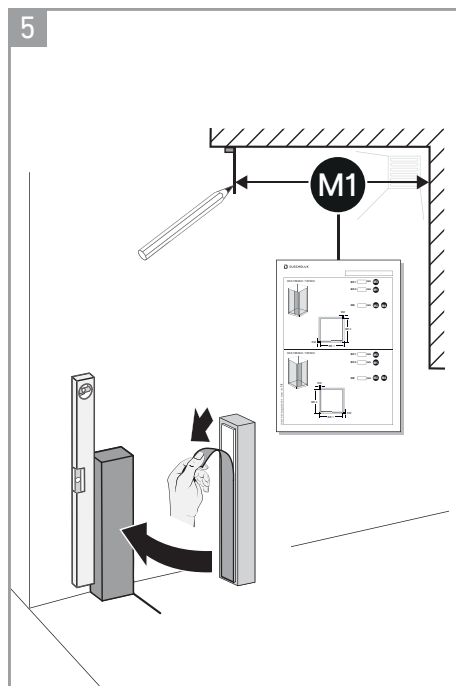
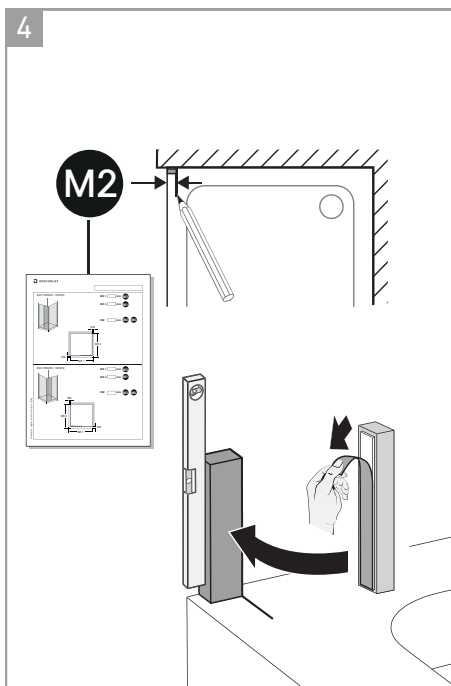
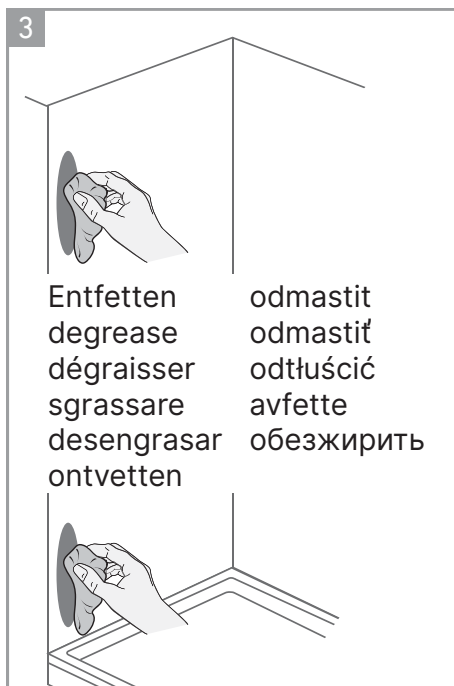
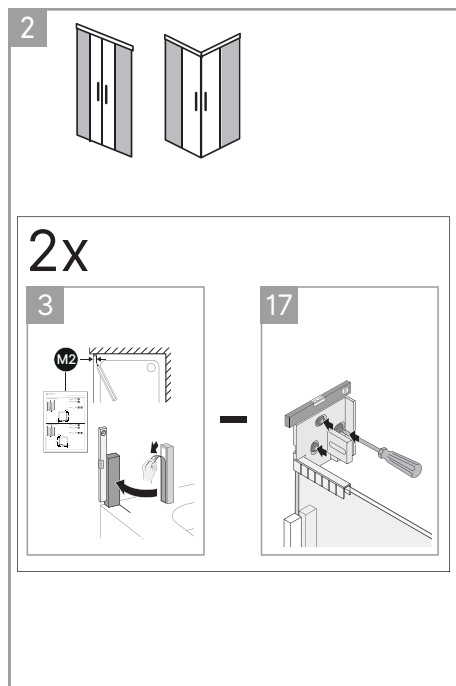
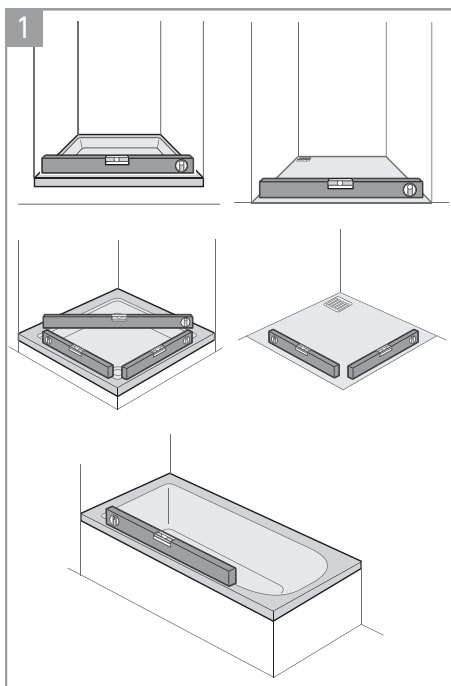

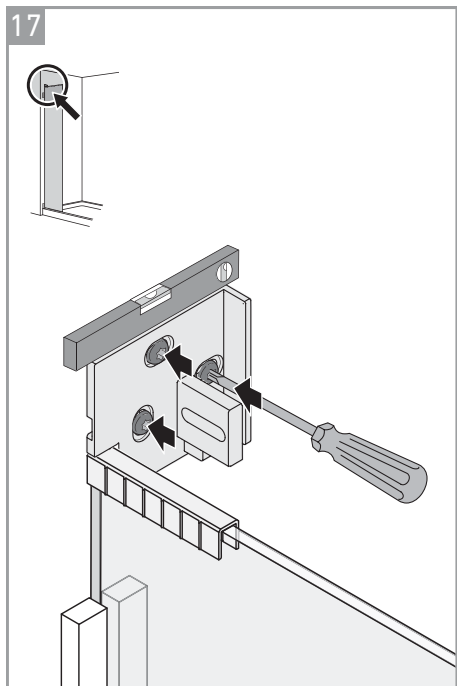
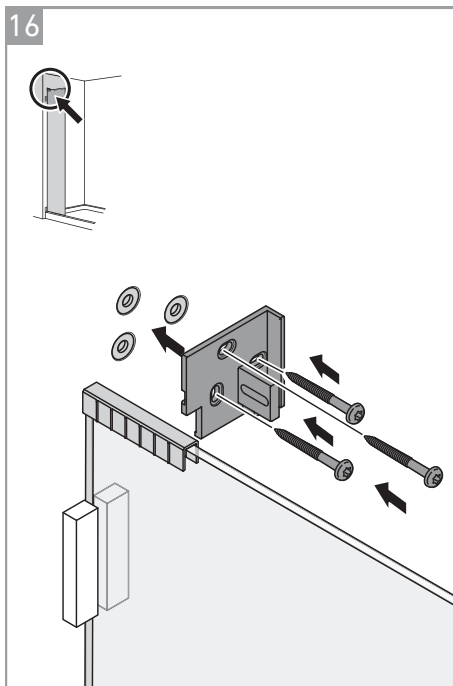
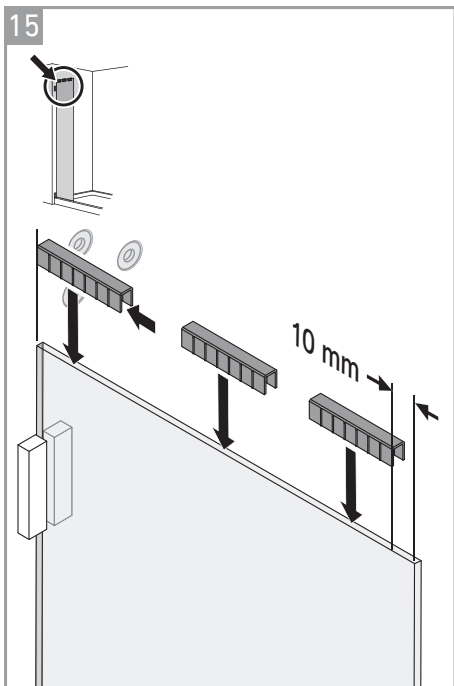
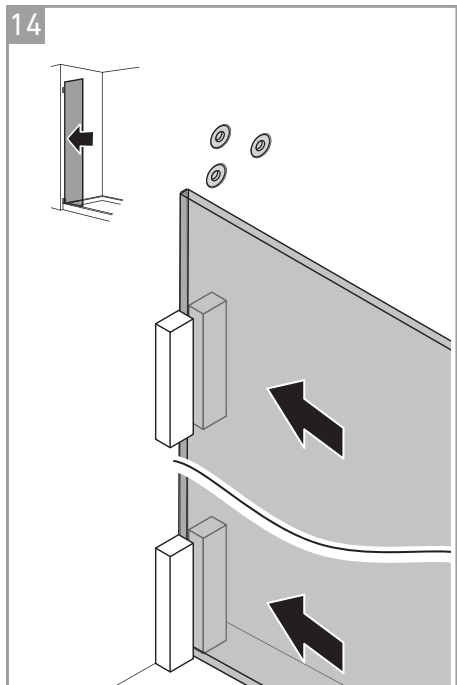
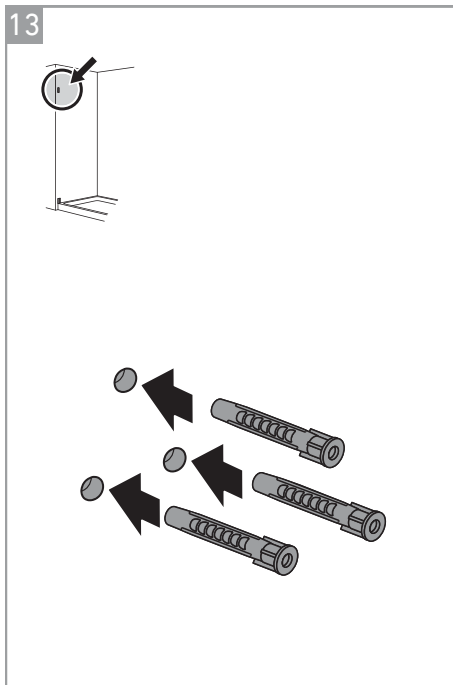
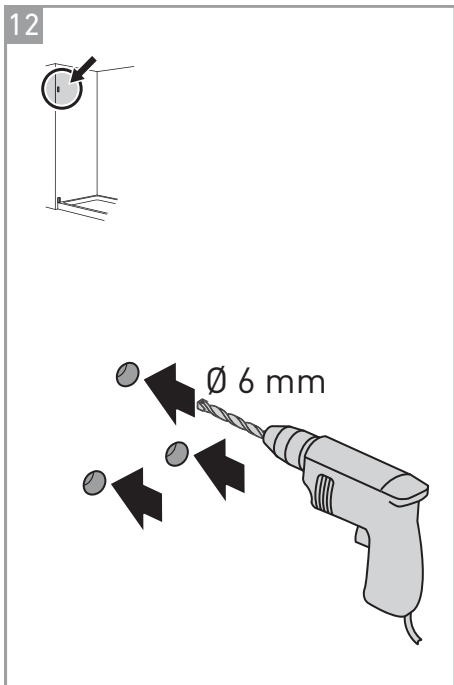
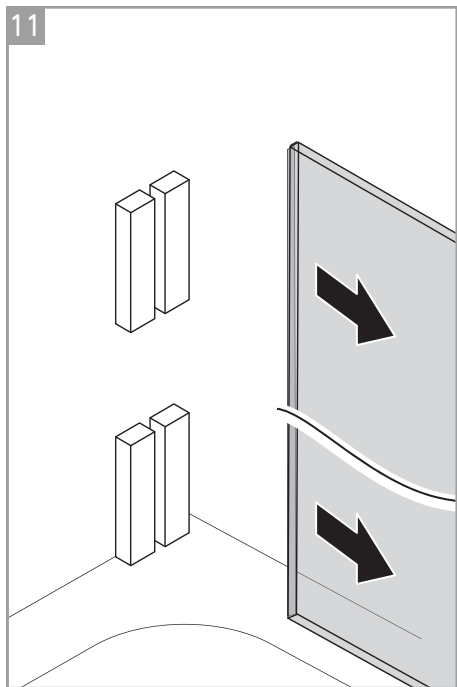
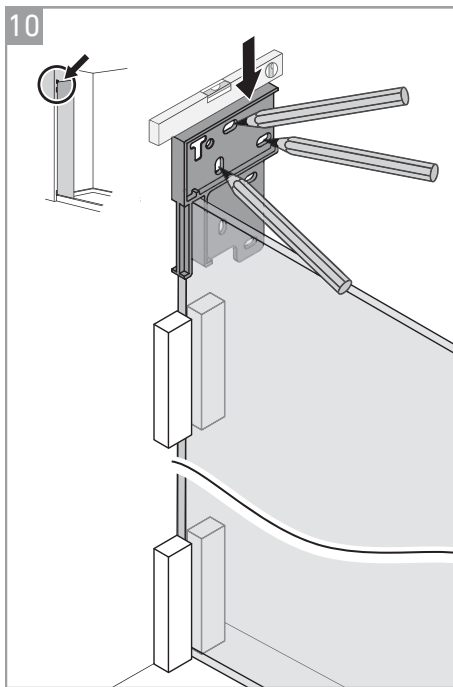
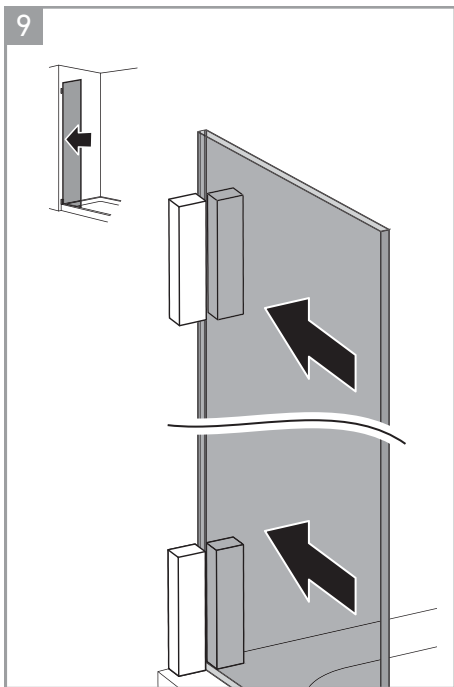

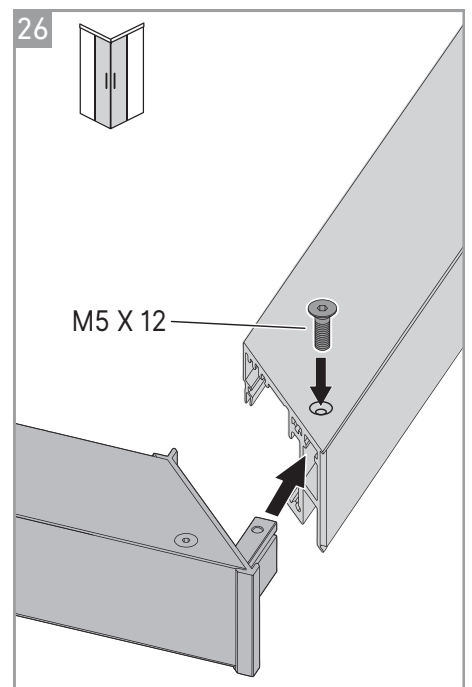
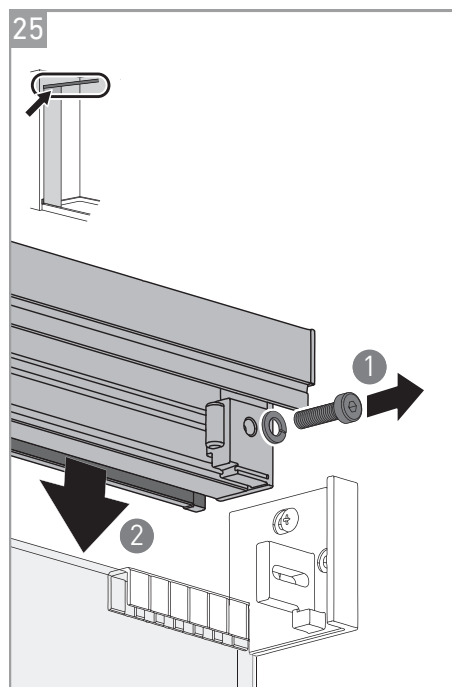
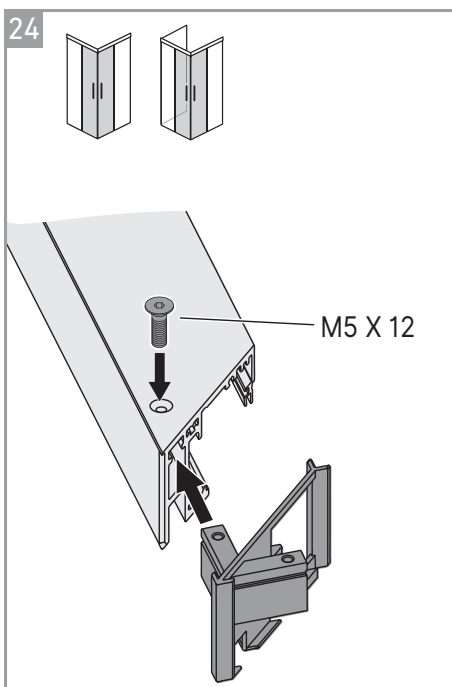
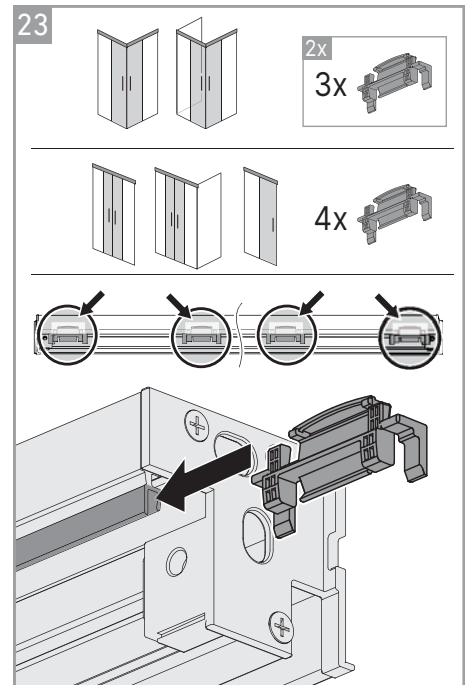
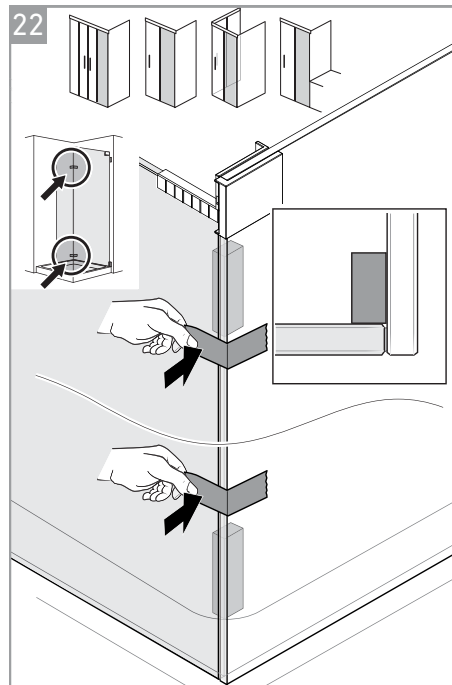
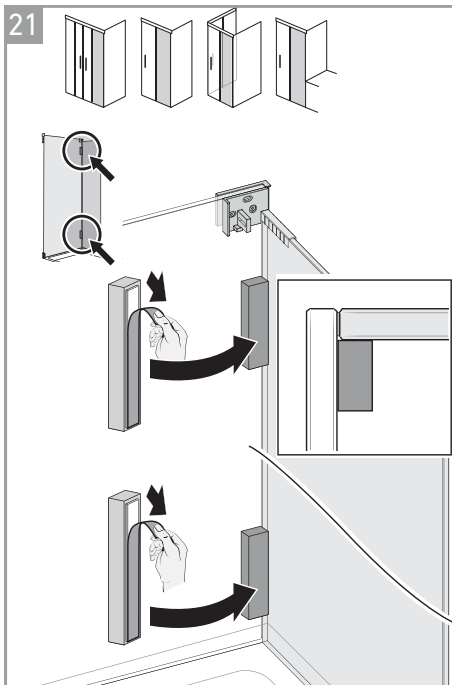
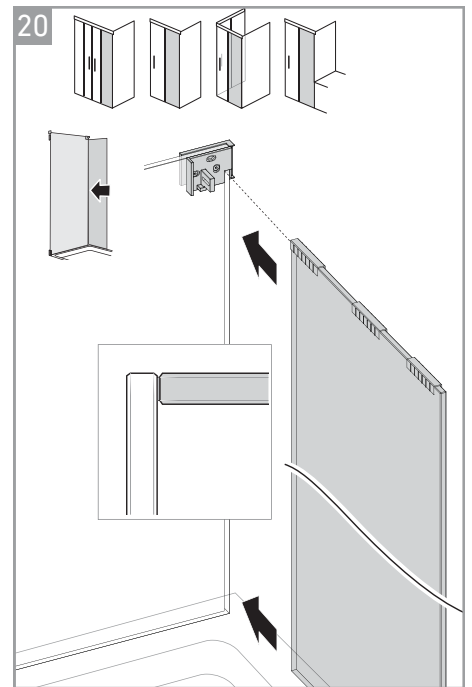
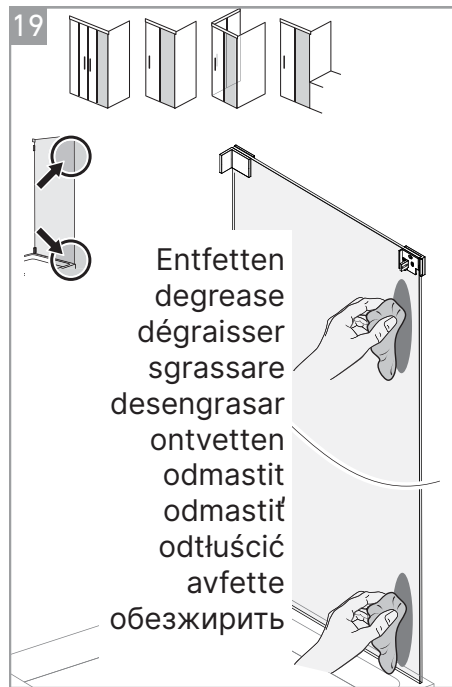
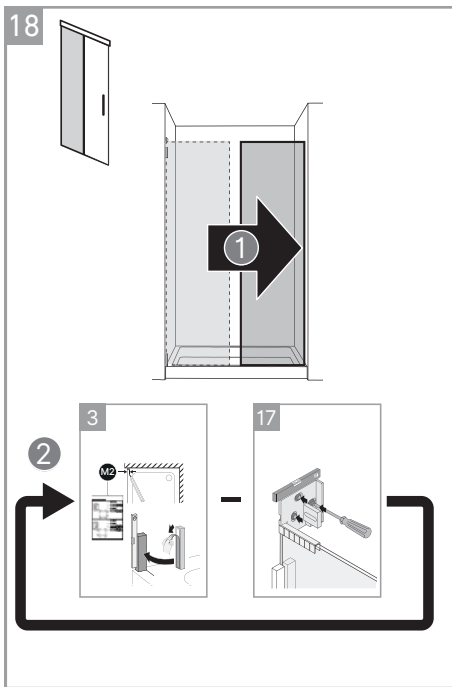

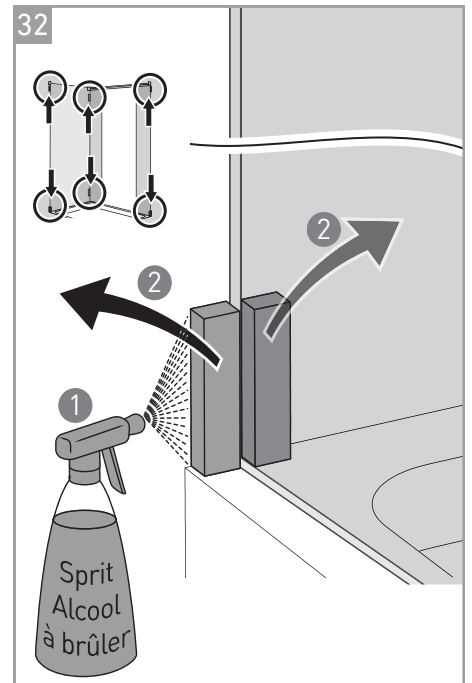
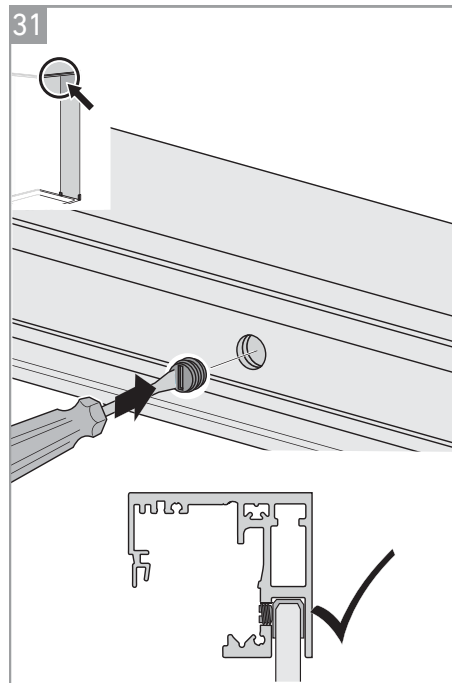
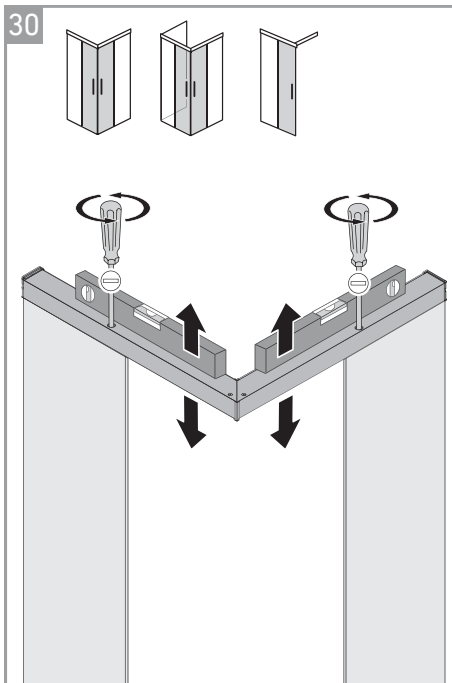
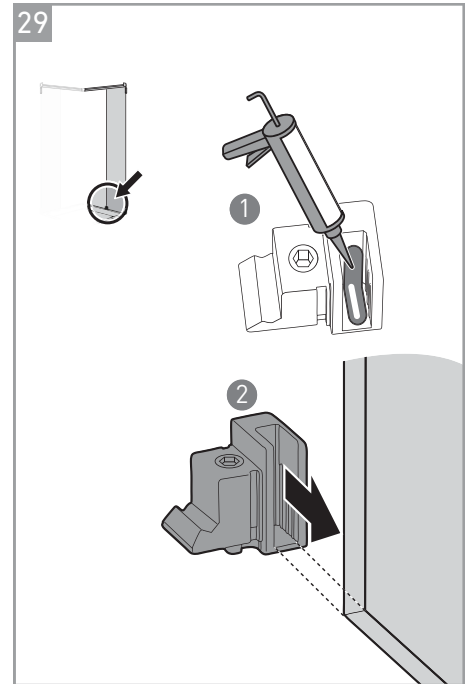
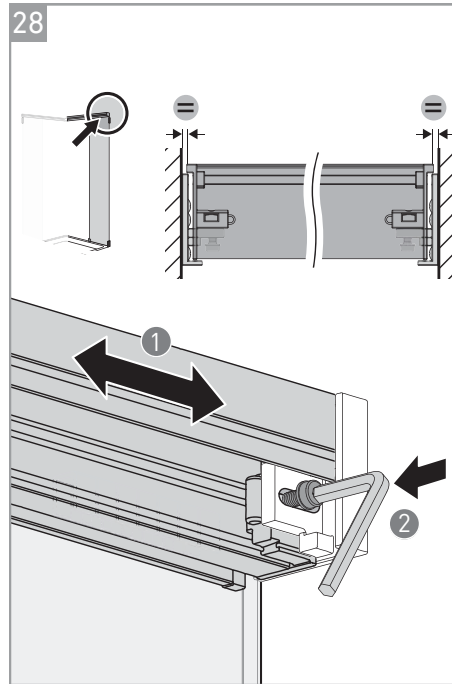
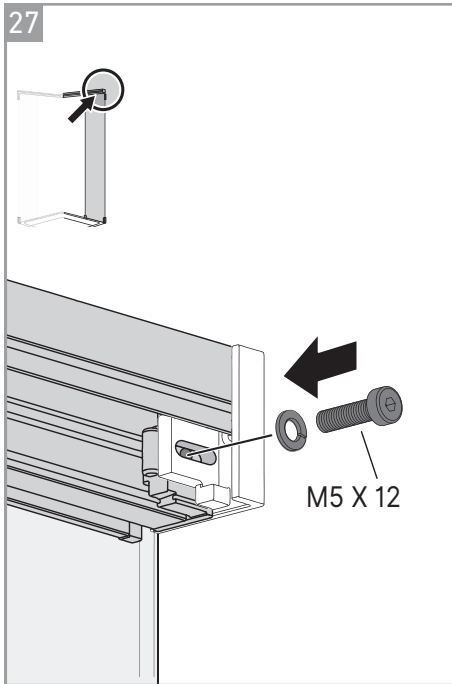

452805

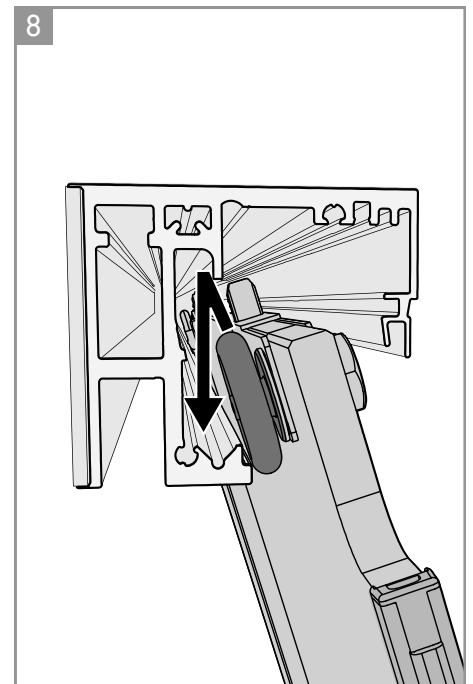
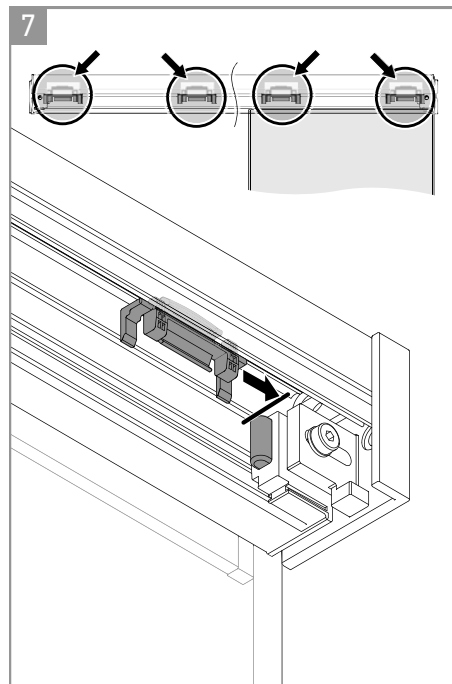
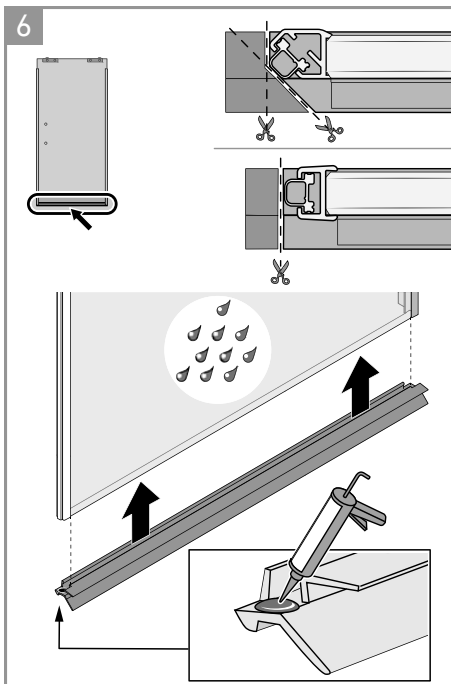
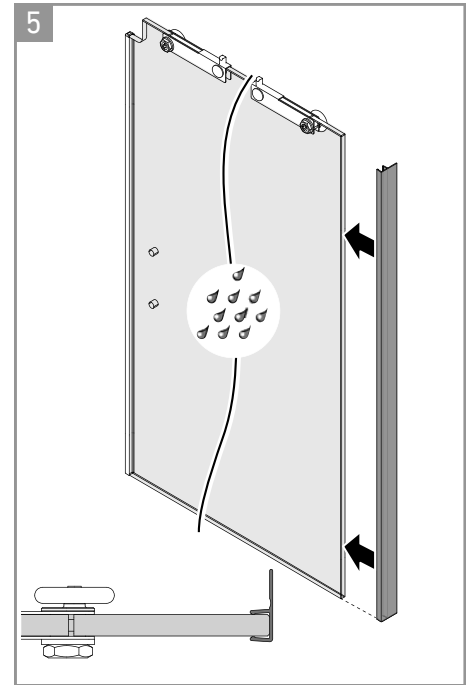
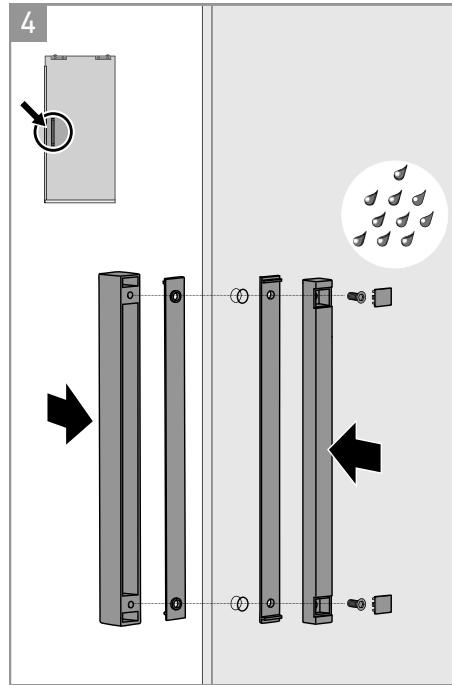
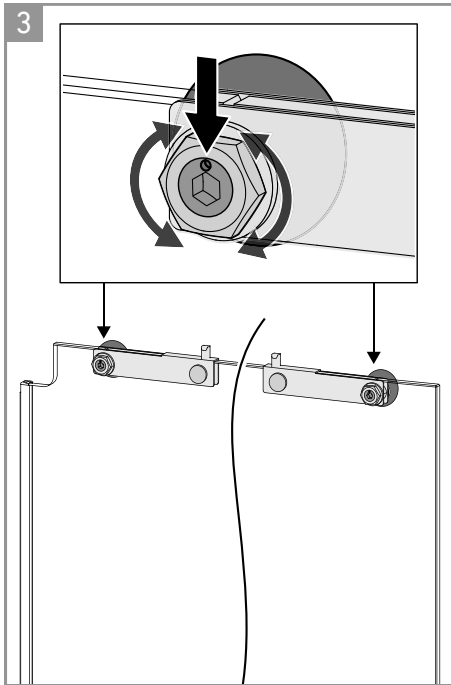
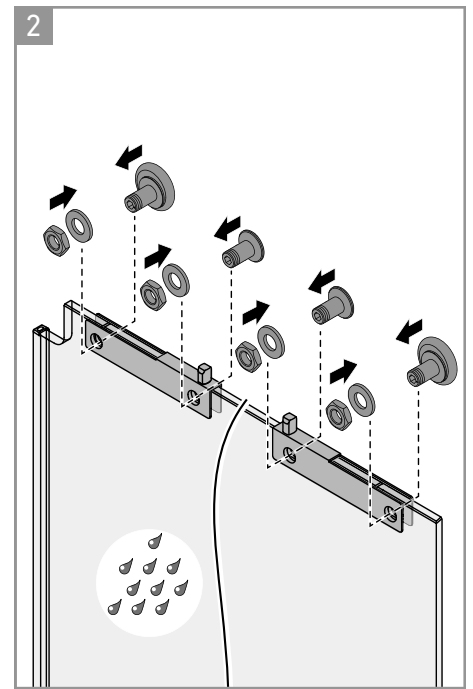
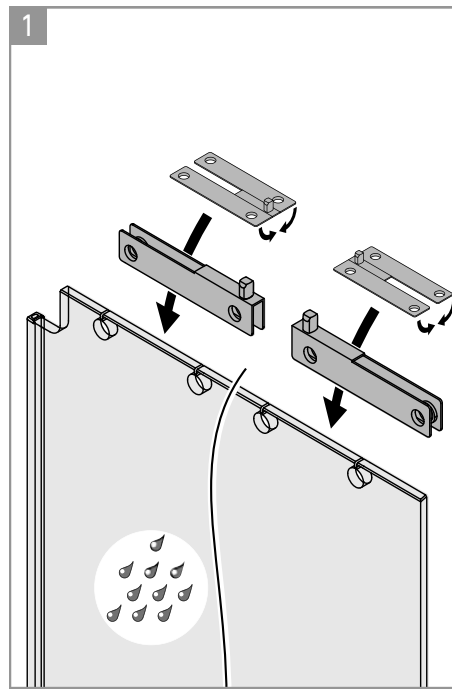
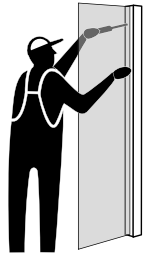

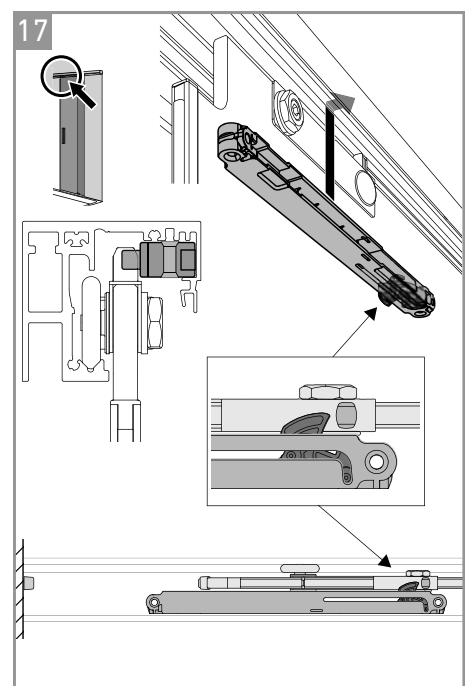
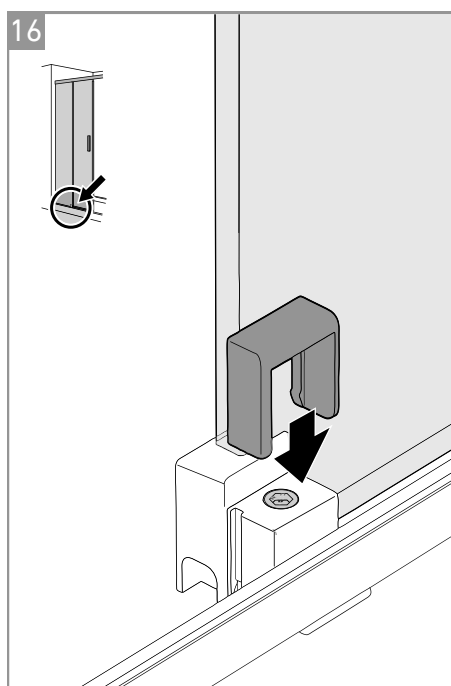
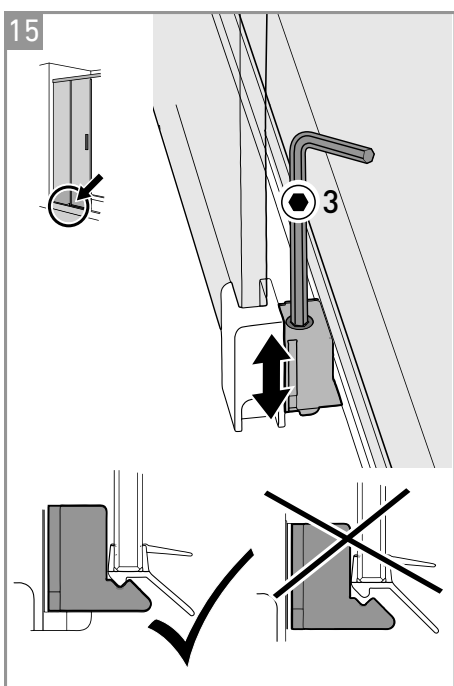
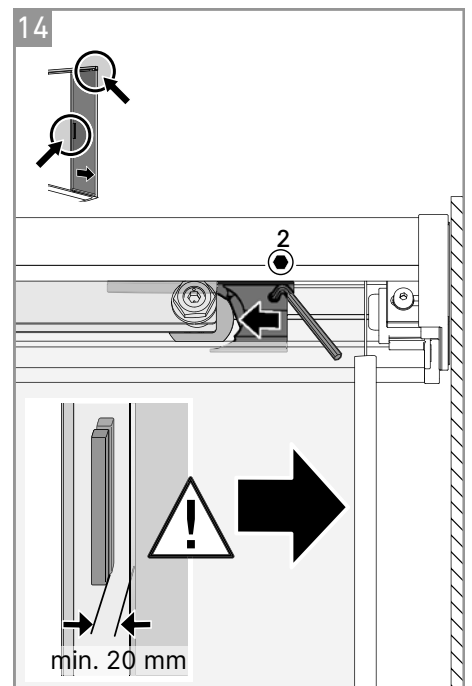
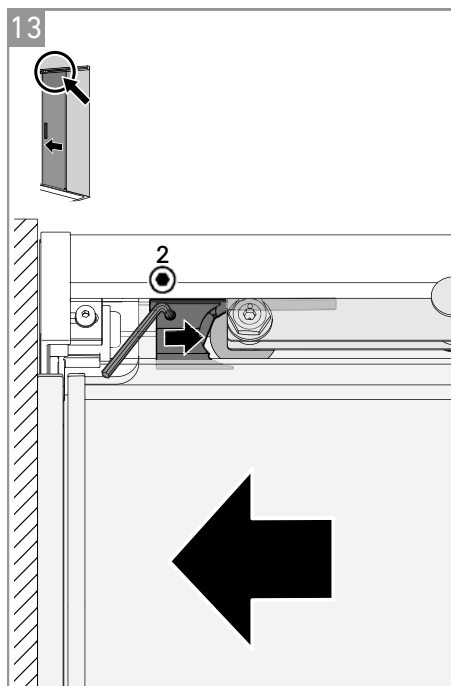
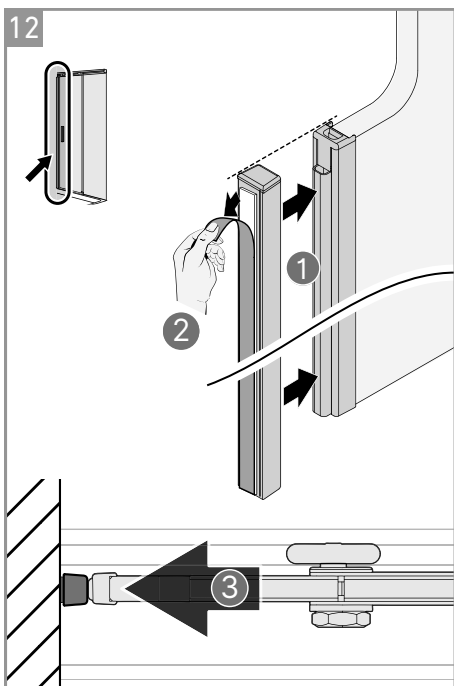
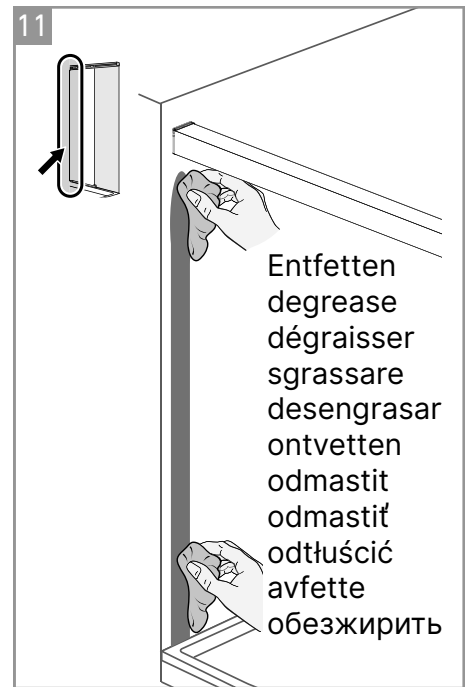
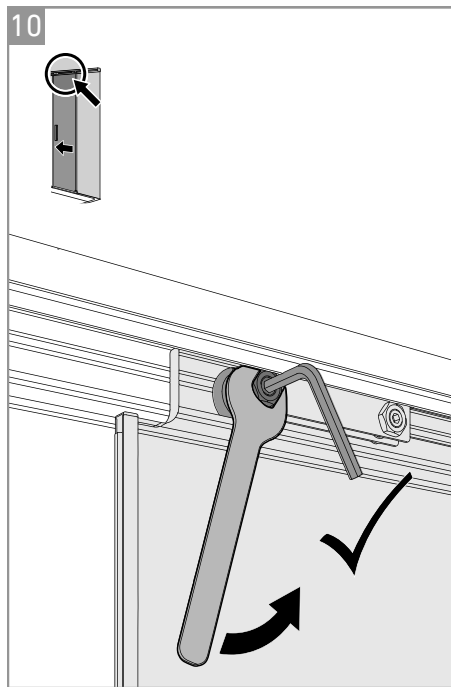
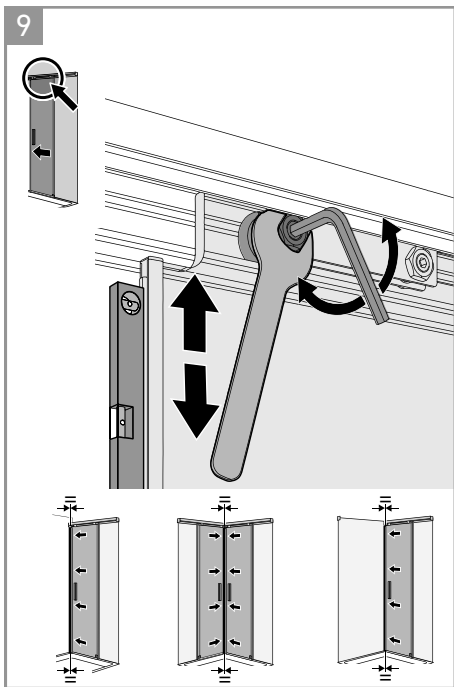

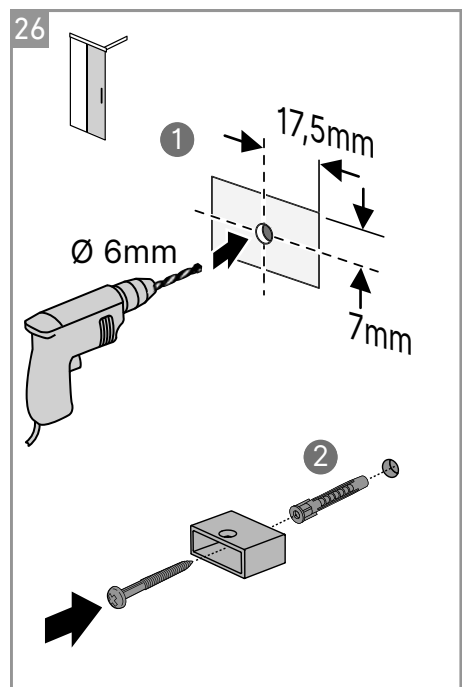
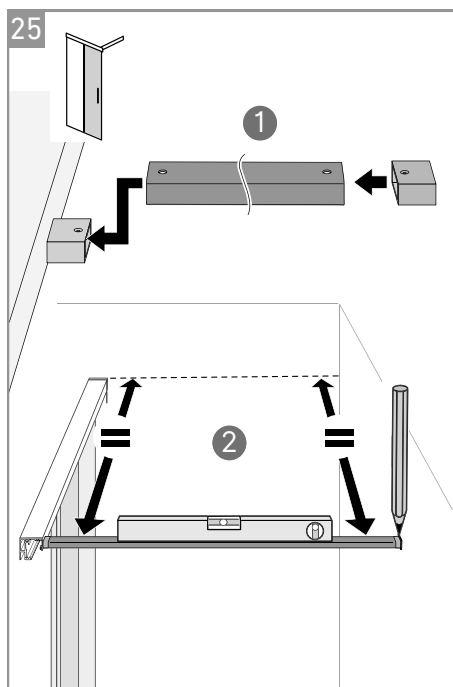
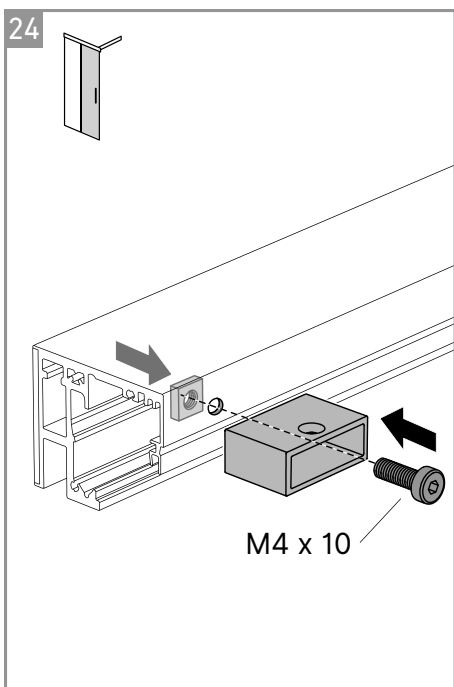
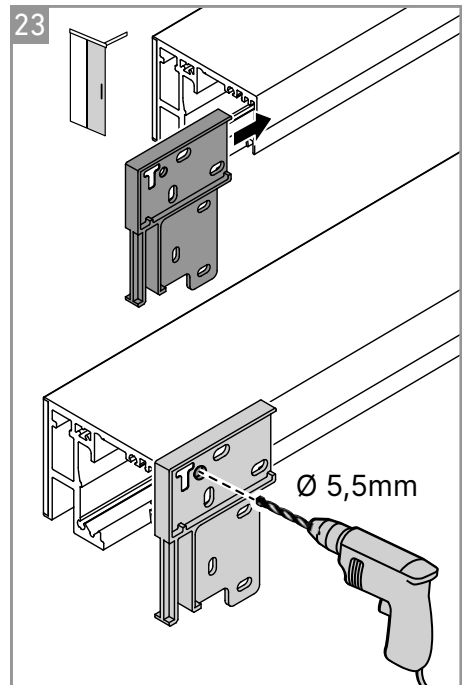
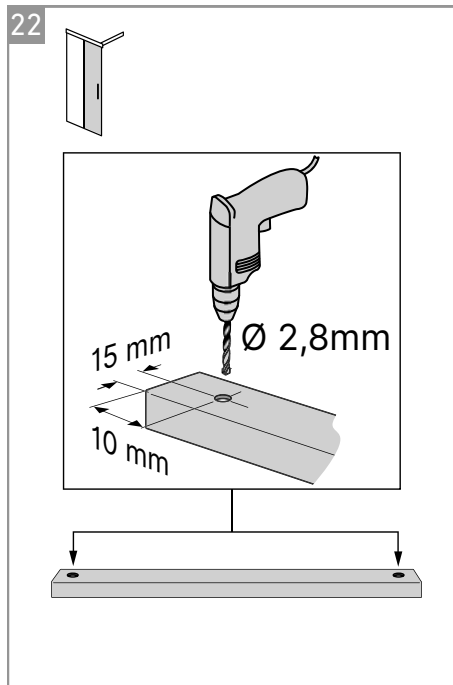
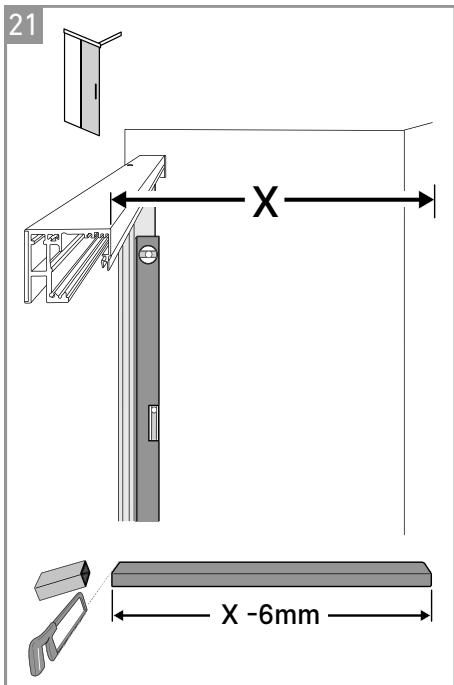
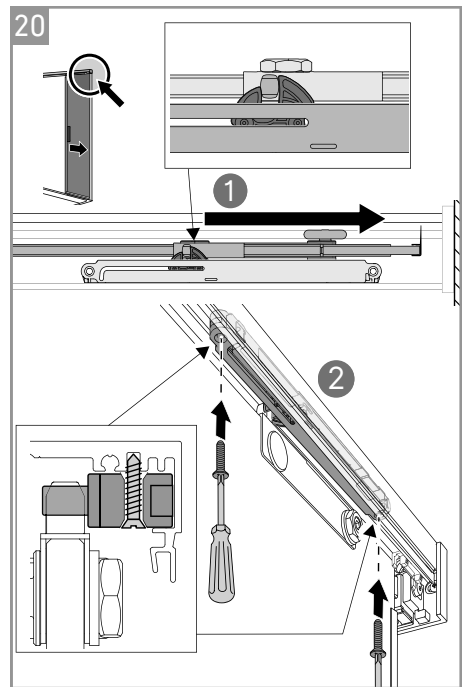
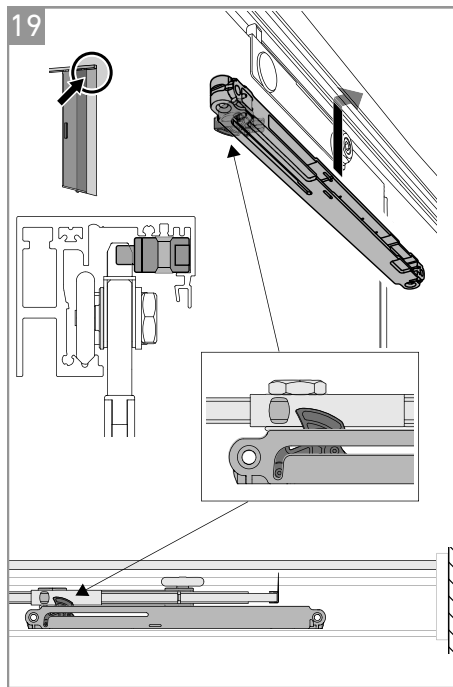
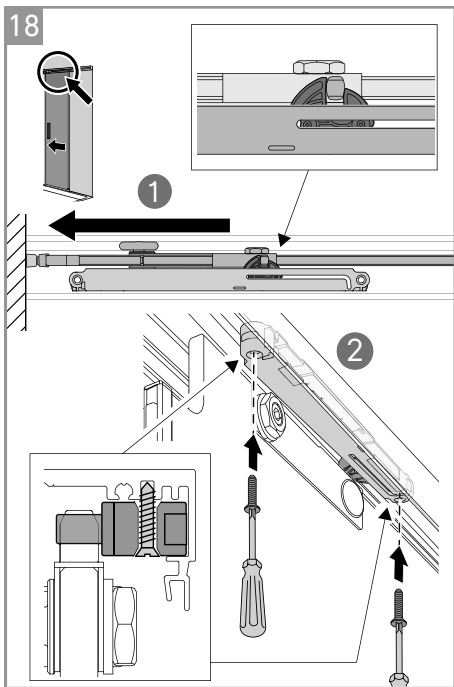

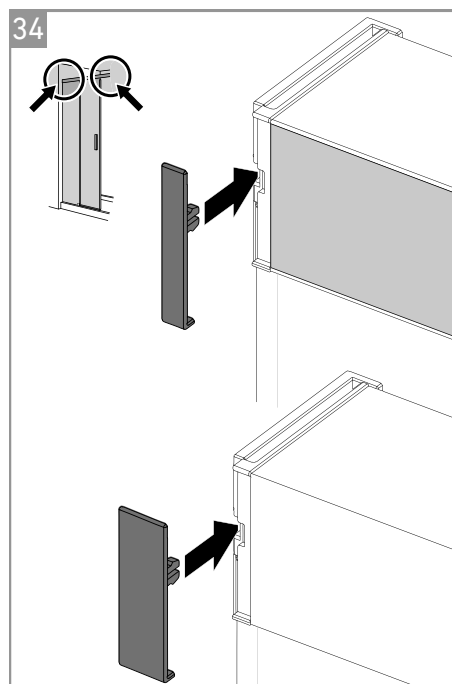
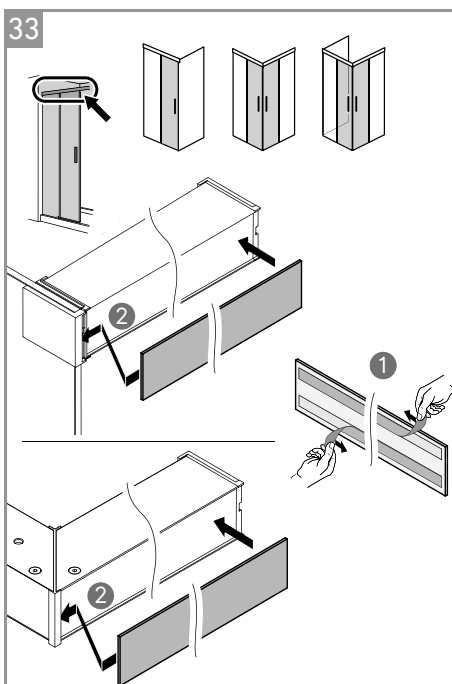
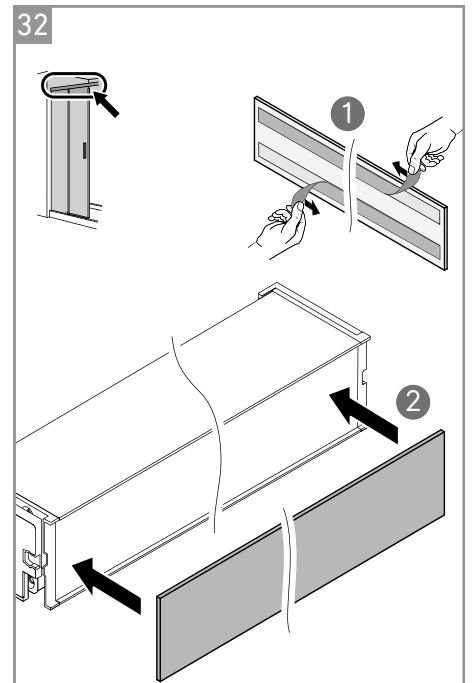
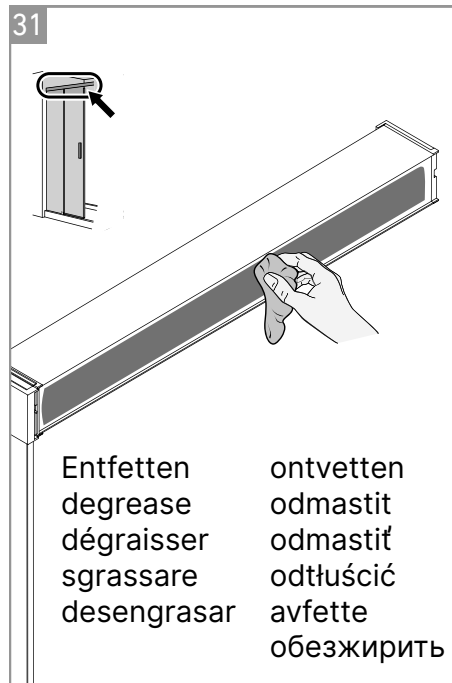
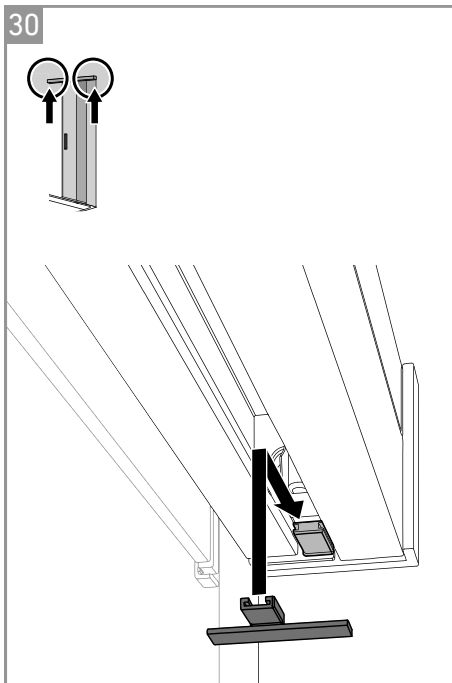
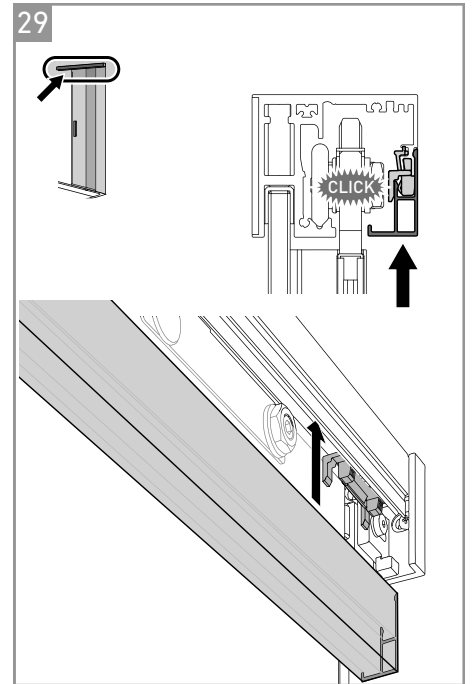
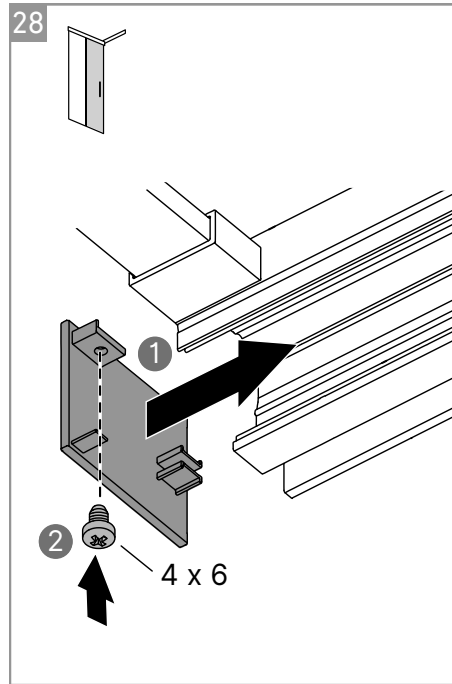
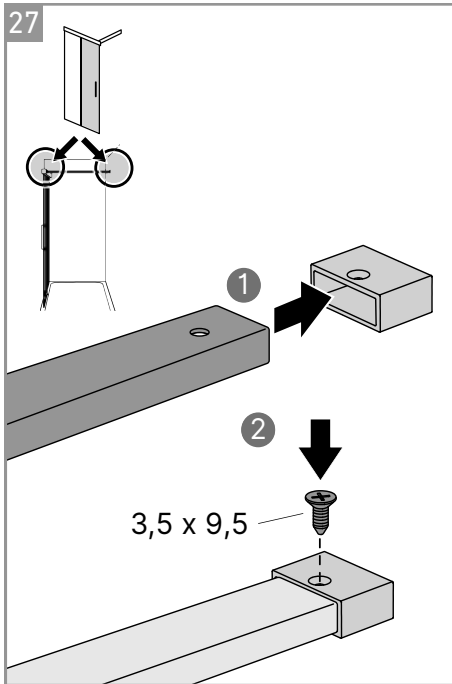

452806

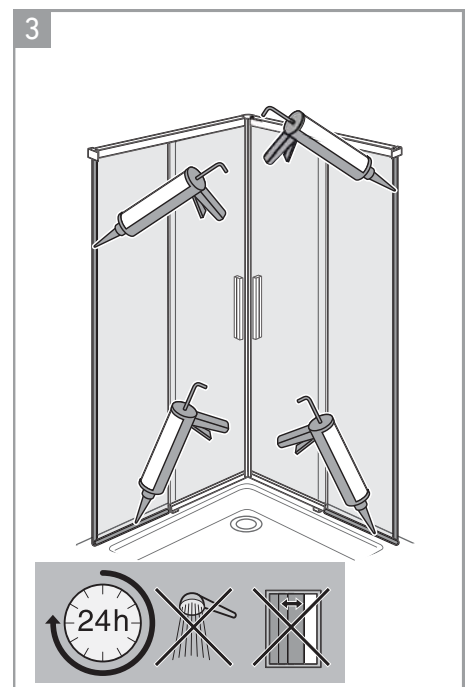
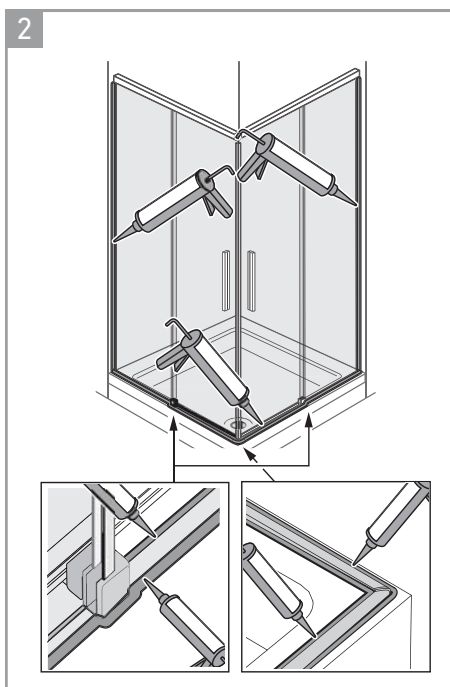
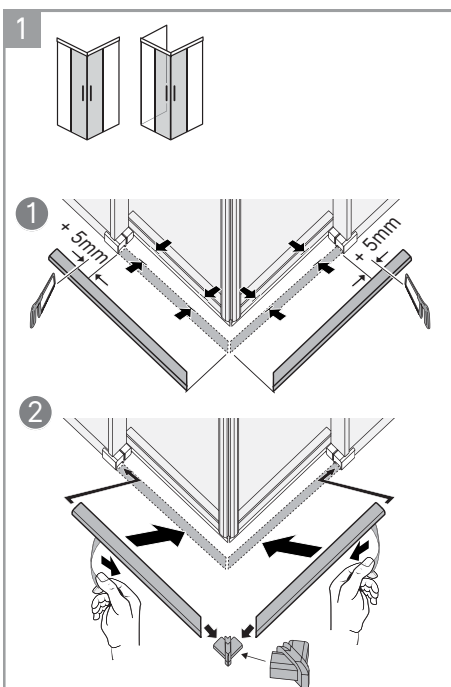
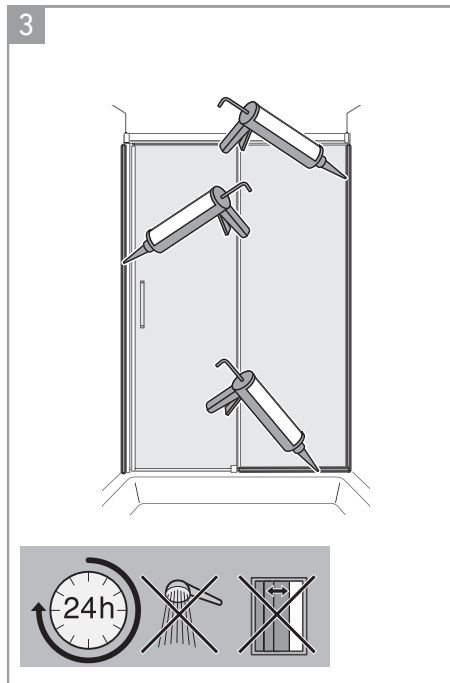
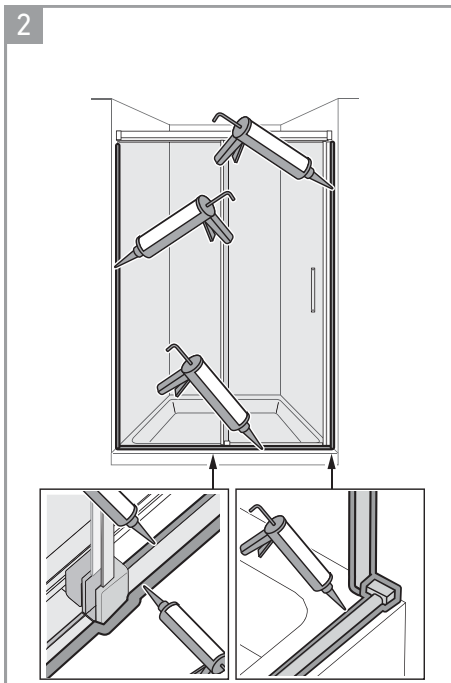
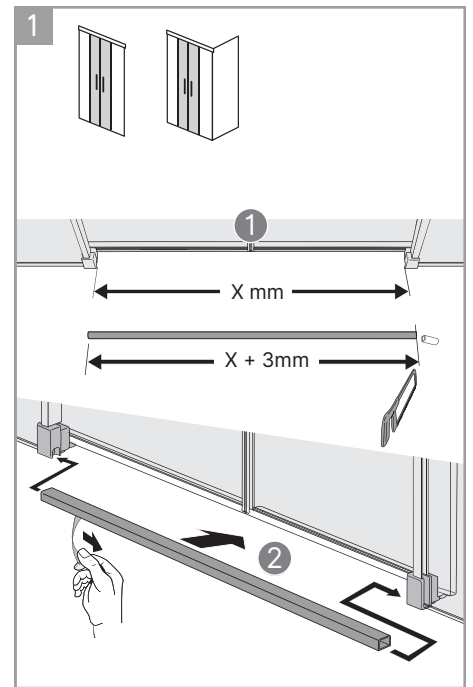
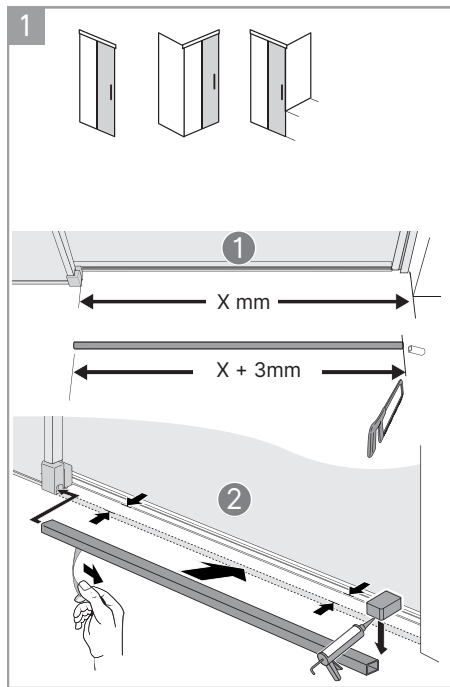

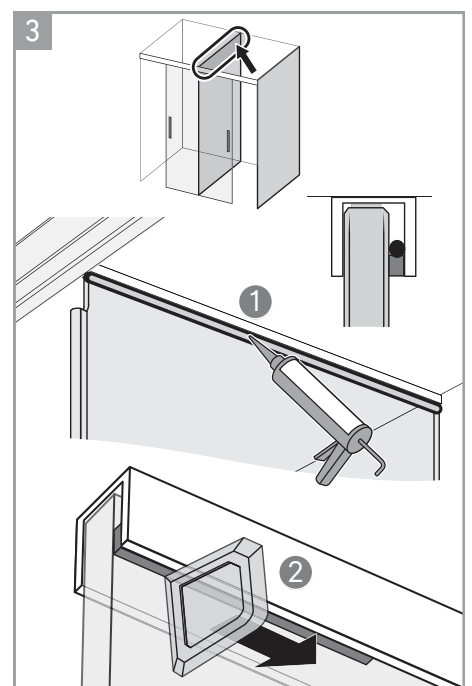
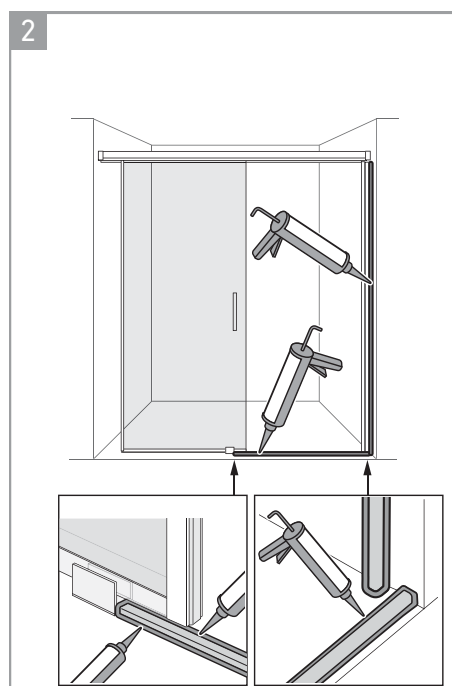
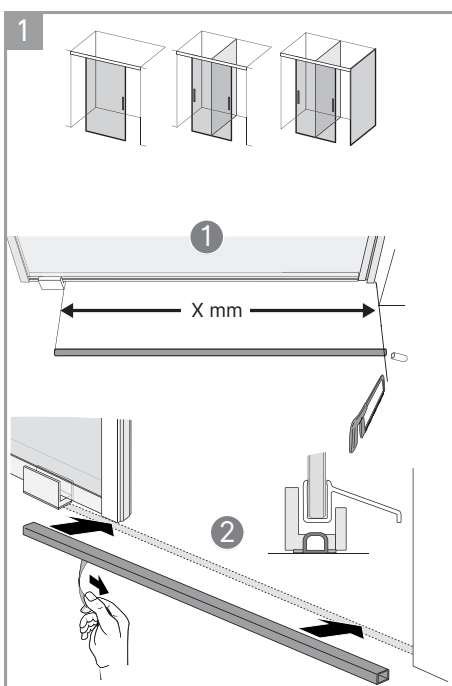
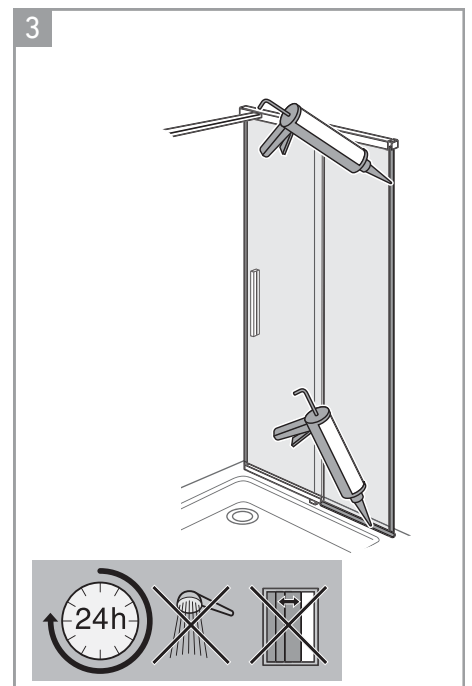
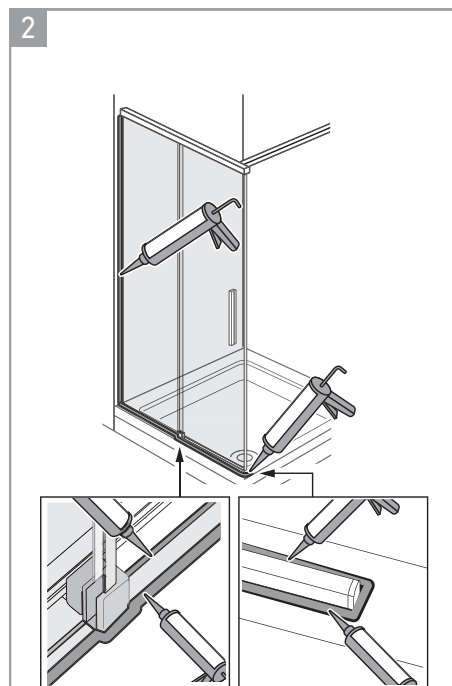
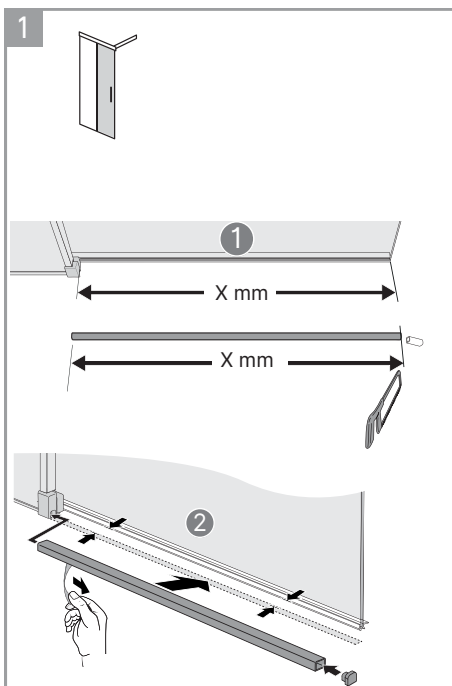
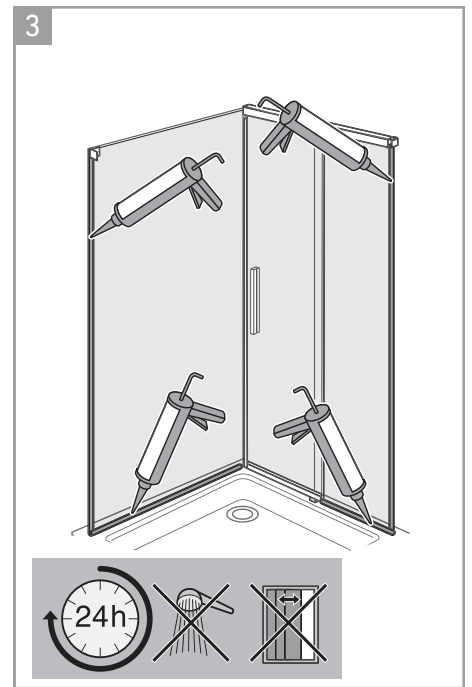
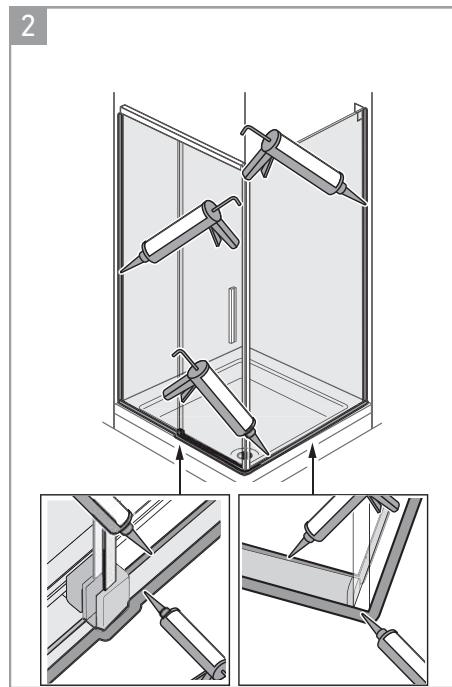
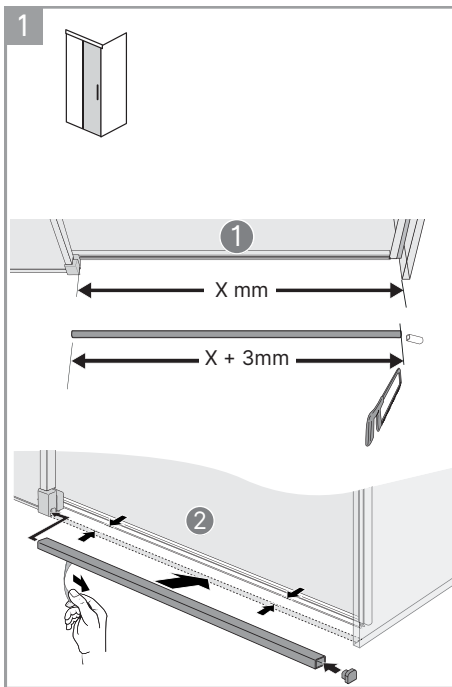

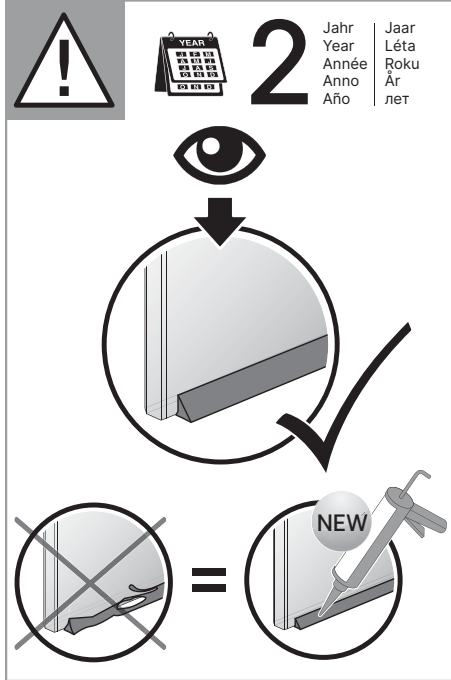
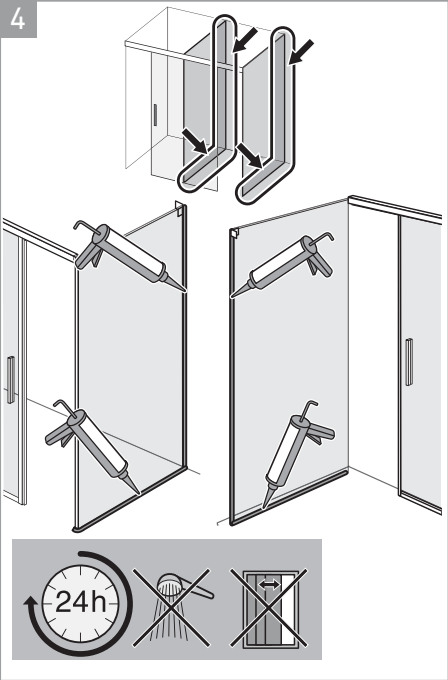

Viva Schiebetür 470.207120

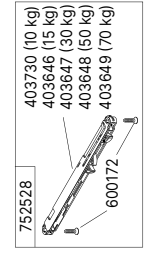
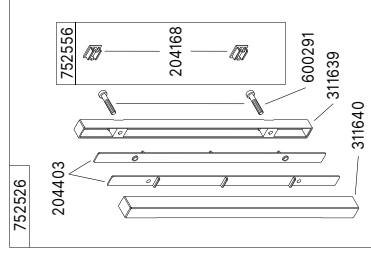
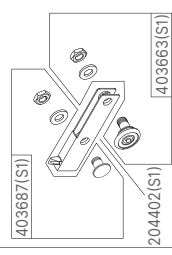
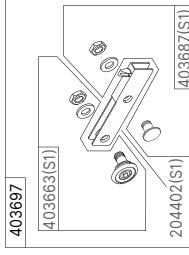
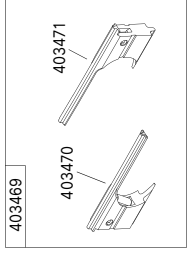
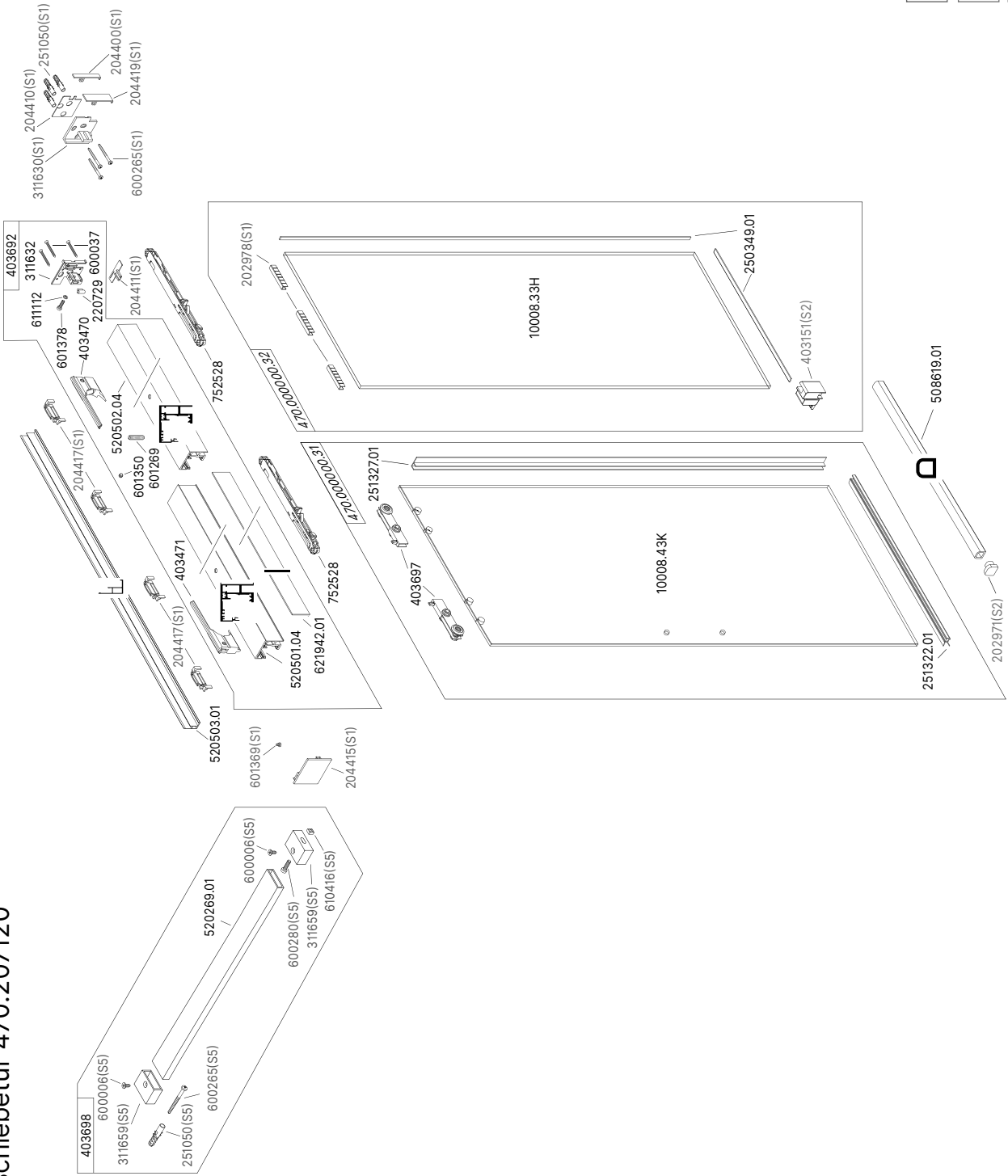

S1 (Set 1) 752558

S2 (Set 2) 752568

S5 (Set 5) 752547